

H-92341 New Street, Evanston to Calvin
&
H-92342 2nd Street, Houston to Muskegon



Project Engineer: Dan VanderHeide

City of Muskegon

Department of Public Works

TABLE OF CONTENTS

INTRODUCTION

INVITATION FOR BIDS2
NOTICE OF REQUIREMENT FOR AFFIRMATIVE ACTION3
DEFINITIONS.....4

PART 1 - BIDS

SECTION 1 – INSTRUCTIONS TO BIDDERS7
1.0 INSTRUCTIONS TO BIDDERS8
SECTION 2 - BID PROPOSAL14
1.1 CONTRACT BIDDER’S CHECKLIST.....15
1.2 TRANSMITTAL LETTER FOR BID PROPOSAL16
1.3 BIDDER CERTIFICATION & AGREEMENT.....17
1.4 BID BOND19
1.5 NON-COLLUSION AFFIDAVIT OF PRIME BIDDER.....21
1.6 LIST OF PROPOSED SUBCONTRACTORS22
1.7 DISADVANTAGED CONTRACTOR AFFIDAVIT23
1.8 STATEMENT OF BIDDER’S QUALIFICATIONS24
1.9 DBE/MBE/WBE PROCUREMENT POLICY26
1.10 BID TABULATUION29

PART 2 - AGREEMENT

2.0 AWARDEE CHECKLIST.....36
2.1 DIRECTIONS FOR PREPARATION37
2.2 AGREEMENT38
2.3 PERFORMANCE BOND.....40
2.4 LABOR & MATERIALMAN’S BOND42
2.5 NON-COLLUSION AFFIDAVIT OF SUBCONTRACTOR.....44
2.6 LETTERS OF RECOMMENDATION IN LIEU OF PERFORMANCE BOND.....45

PART 3 – GENERAL SPECIFICATIONS

SECTION 1 – PROJECT PERFORMANCE47
3.0 PROJECT PERFORMANCE48
3.1 TIME CHANGE ORDER64
3.2 CONTRACT CHANGE ORDER.....65
3.3 CONTRACTOR'S CERTIFICATE & RELEASE REQUEST FOR FINAL PAYMENT.....66
3.4 CONTRACTOR AFFIDAVIT - SURETY RELEASE68
3.5 CONSENT OF SURETY69
SECTION 270
3.6 AFFIRMATIVE ACTION71
SECTION 372
3.7 ADOPTED LABOR STANDARDS PROVISIONS73
3.8 EQUAL OPPORTUNITY CLAUSE.....74
3.9 ANTI-KICKBACK ACT.....75
SECTION 476
3.10 PREVAILING WAGE DECISION77

PART 4 – ENGINEERING SPECIFICATIONS

CITY OF MUSKEGON - STANDARD CONSTRUCTION PLANS79

PART 5 - SPECIAL SPECIFICATIONS

ALL PAY ITEMS.....153
PROGRESS CLAUSE.....154
UTILITY COORDINATION156
DR STRUCTURE, REM, MODIFIED158
PAVT, REM, MODIFIED159
MACHINE GRADING MODIFIED.....162
SEWER, DUCTILE IRON166
CATCH BASIN, _ FT ID, SPECIAL DETAIL168
DR STRUCTURE COVER, TYPE __, MODIFIED.....168
DR STRUCTURE COVER, ADJ, ADD DEPTH, MODIFIED168
DR STRUCTURE COVER, ADJ, CASE I, MODIFIED.....171
HMA ACCEPTANCE172
DRIVEWAY, NONREIF CONC, _ INCH, MOD
CURB AND GUTTER, CONC, DET __, MODIFIED.....179
MAINTAINING TRAFFIC.....180
MINOR TRAF DEVICES AND TRAF REGULATOR CONTROL183
HYDROSEEDING185
WATER SERVICE, _ INCH.....186
WATER SERVICE, PRIVATE PROPERTY188
METER PIT COMPLETE.....203
VALVE, _ INCH, GATE, WITH BOX.....206
AUTOMATED MACHINE GUIDANCE.....208
IRRIGATION REPAIRS.....212

PART 6 - MDOT SPECIFICATIONS

R-28-K SIDEWALK RAMP AND DETECTABLE WARNING DETAILS215
R-29-J DRIVEWAY OPENINGS AND APPROACHES AND CONCRETE SIDEWALKS222
R-30-G CONC CURB AND GUTTER.....226

APPENDICIES (TO BE COMPLETED AFTER CONTRACT AWARD)

PRE-BID DOCUMENTS Appendix Page
 PRE-BID MEETING MINUTES Appendix Page
SIGNED BIDDER DOCUMENTS Appendix Page
 TRANSMITTAL LETTER FOR BID PROPOSAL Appendix Page
 BIDDER CERTIFICATION AND AGREEMENT Appendix Page
 BID TABULATION Appendix Page
 BID BOND PROPOSAL..... Appendix Page
 GENERAL POWER OF ATTORNEY..... Appendix Page
 NON-COLLUSION AFFIDAVIT OF PRIME BIDDER..... Appendix Page
 LIST OF PROPOSED SUBCONTRACTORS..... Appendix Page
 DISADVANTAGED CONTRACTOR AFFIDAVIT Appendix Page
SIGNED AGREEMENT DOCUMENTS Appendix Page
 AGREEMENT Appendix Page
 PERFORMANCE BOND Appendix Page
 LABOR & MATERIALMAN’S BOND..... Appendix Page
 POWER OF ATTORNEY Appendix Page
 NON-COLLUSION AFFIDAVIT OF SUBCONTRACTOR Appendix Page

CERTIFICATE OF LIABILITY INSURANCE Appendix Page
ATTORNEY APPROVAL LETTER..... Appendix Page

INTRODUCTION

INVITATION FOR BIDS

**Project: H92341 New Street, Evanston to Calvin
H92342 2nd Street, Houston to Muskegon**

The City of Muskegon, Michigan will receive sealed bids until 2:00 p.m. local time on Tuesday, May 28, 2024, at the City Clerk's Office, City Hall, 933 Terrace Street, Muskegon, Michigan, at which time and place all bids will be publicly opened and read aloud for the following items of work to include:

CONSTRUCTION INCLUDES 0.37 MILES OF HMA PAVEMENT RECONSTRUCTION; INCLUDING HMA REMOVAL, HMA PAVEMENT, WATER SERVICES, STORM SEWER, CONCRETE SIDEWALKS, AND CURB & GUTTER ON NEW ST IN THE CITY OF MUSKEGON, MUSKEGON COUNTY.

CONSTRUCTION INCLUDES 0.11 MILES OF HMA PAVEMENT RECONSTRUCTION; INCLUDING HMA REMOVAL, HMA PAVEMENT, STORM SEWER, WATER SERVICES, CONCRETE SIDEWALKS, CURB RAMP, CURB & GUTTER ON SECOND ST; HOUSTON AVE IN THE CITY OF MUSKEGON, MUSKEGON COUNTY.

Electronic copies of Plans and Specifications may be obtained on or after Friday, January 3, 2020 from the City of Muskegon website, or by request to the Engineering Department via phone or email; 231.724.6707 or engineering@shorelinecity.com. Printed copies can be obtained by request from the Engineering Department located at 1350 E. Keating Ave, Muskegon MI, 49442 for a cost of \$40.

An amount equal to five percent (5%) of the Bid must be submitted with each Bid Proposal in one of three forms acceptable to the City of Muskegon.

Contract documents may be examined at the following locations:

- Public Services Building, 1350 E. Keating Ave., Muskegon MI 49442
- City of Muskegon website: www.shorelinecity.com
- Grand Rapids Builders Exchange

A Pre-Bid Conference will be held in the Conference Room at the City of Muskegon Public Services Building located at 1350 E Keating Avenue at 10:00am on Wednesday, May 15, 2024, at which time and place any questions regarding this Project should be presented. Minutes from the Pre-Bid Conference will become an Addendum to the Contract.

CITY OF MUSKEGON, MICHIGAN

By: Ann Meisch, City Clerk

PUBLISH: 05/03/2024

ADA POLICY

The City will provide necessary appropriate auxiliary aids services, for example, signers for the hearing impaired, audio tapes for the visually impaired, etc., for disabled persons who want to attend the meeting, upon twenty-four hour notice to the City.

Contact:

Ann Meisch, City Clerk
City of Muskegon, City Hall
933 Terrace Street, Muskegon, MI 49440
(231) 724-6705 or TDD (231) 724-6773

NOTICE OF REQUIREMENT FOR AFFIRMATIVE ACTION

Executive Order 11246

1. The Bidder's attention is called to the "Equal Opportunity Clause" and the "Standard Adopted Equal Employment Specifications" set forth in Part 3, Section II, of these Documents.
2. The goals and the timetables for minority and female participation, expressed in percentage terms for the Contractor's aggregate workforce in each trade on all construction work in the covered area, are as follows:

GOALS FOR PARTICIPATION IN EACH TRADE

TRADE	MINORITY	FEMALE
ALL	14%	6.9%

These goals are applicable to all the Contractor's construction work (whether or not it is Federal or Federally-assisted) performed in the covered area. If the Contractor performs construction work in a geographical area located outside of the covered area, it shall apply the goals established for such geographical area where the work is actually performed. With regard to this second area, the Contractor also is subject to the goals for both its federally involved and non-federally involved construction.

The Contractor's compliance with the Executive Order and regulations in 41 CFR Part 60-4 shall be based on its implementation of the Equal Opportunity Clause, specific affirmative action obligations required by the specifications set forth in 41 CFR 60-4.3(a), and its efforts to meet the goals. The hours of minority and female employment and training must be substantially uniform throughout the length of the Contract, and in each trade, and the Contractor shall make a good faith effort to employ minorities and women evenly on each of its projects. The transfer of minority or female employees or trainees from contractor to contractor or from project to project for the sole purpose of meeting the contractor's goals shall be a violation of the Contract, the Executive Order, and the regulations in 41 CFR Part 60-4. Compliance with the goals will be measured against the total work hours performed.

3. The Contractor shall provide written notification to the Director of the Office of Federal Contract Compliance Programs within 10 working days of award of any construction subcontract in excess of \$10,000 at any tier for construction work under the Contract resulting from this solicitation. The notification shall list the name, address and telephone number of the subcontractor; employer identification number of the subcontractor; estimated dollar amount of the subcontract; estimated starting and completion dates of the subcontract; and the geographical area in which the contract is to be performed.
4. As used in this Notice, and in the Contract resulting from this solicitation, the "covered area" is the City of Muskegon, County of Muskegon, and State of Michigan.

DEFINITIONS

Whenever used anywhere in these Documents, the following meanings shall be given to the terms defined:

ADDENDA or ADDENDUM – Any changes, revisions, additions or clarifications of or to the Contract Documents which have been duly issued by the City to Bidders prior to the time of awarding or executing the Contract Agreement.

AUTHORIZED REPRESENTATIVE – Any person or persons authorized to represent the City of Muskegon by its governing body for the purpose of directing or having in charge the work embraced in this Contract, acting directly or indirectly through the responsible party having general charge of this work, and/or for monitoring, coordinating and inspecting the work and activities involved.

BID or BID PROPOSAL – The written offer of the Bidder, on the form furnished by the City, for the work proposed.

BID BOND/GUARANTY – The security required in these Documents and furnished by the Bidder as a guaranty of good faith to enter into a contract for the work proposed.

BIDDER or PRIME BIDDER – That individual, corporation or firm submitting a proposal for consideration by the City to perform the work proposed in these Documents.

CITY – CITY OF MUSKEGON - The City of Muskegon and/or its authorized representative(s); also may be referred to in portions of these Documents as owner, grantee, local public agency, or local government.

CITY COMMISSION – The governing body of the City of Muskegon which retains the right of final approval of all contractors, subcontractors, contracts and payments under any contracts.

CONTRACT – The Agreement executed by the City and the Contractor, of which this section is a part.

CONTRACT DOCUMENTS – Means and shall include the executed Agreement, any Addenda, Invitation for Bids, Instructions to Bidders, signed Bid Proposal, all Parts and Sections of the General, Technical and/or Special Specifications, any drawings, maps, plans, etc., and any forms or formats and documents included within the book forming these Documents.

CONTRACT PERFORMANCE – The act of complying with these Contract Documents to the successful completion of the Project by performing the work necessary to do so.

CONTRACT PRICE – That figure agreed upon through the bidding procedure as acceptable to the City and indicated as such in the Agreement executed by the Contractor and the City.

CONTRACT TIME – The date for completion or length of time until completion, of the work embraced in this Contract as stipulated in the Agreement executed by the Contractor and the City.

CONTRACTOR or SUCCESSFUL BIDDER – The person, corporation or firm whose bid was accepted by the City, resulting in the execution of the Agreement to perform the work under the terms of these Documents.

DRAWINGS/PLANS – Approved drawings or reproduction of drawings pertinent to the construction or details of the work covered by this Contract.

LABORATORY – The testing laboratory of the City or any other laboratory which may be designated by the City for the purpose of inspecting, examining and determining the suitability of materials and the quality of the products used in the performance of this Contract.

LETTERS OF RECOMMENDATION – IN LIEU OF PERFORMANCE BOND – Those statements presented by the Bidder to the City for consideration in lieu of a performance bond where applicable and in strict accordance with Part 1, Section I, paragraph 17(e), and the instructions in these Documents.

PERFORMANCE/LABOR AND MATERIALMEN’S BONDS – The statutory bonds, executed by the Contractor and a surety, guaranteeing the performance of the Contract and the payment of all lawful indebtedness pertaining thereto.

PREVAILING WAGE DECISION - That document, received from the U.S. Department of Housing and Urban Development or the State of Michigan Department of Labor as requested by the City, detailing the current wage rates which, if included in this Contract, are binding upon the Contractor and all subcontractors as the minimum wages to be paid during the life of this Contract.

SITE – Also referred to as PROJECT SITE or PROJECT AREA, indicating the location of the Project as generally described in these Documents.

SUBCONTRACT – An agreement executed by the Contractor with another individual, corporation or firm for work or a portion of the work embraced in this Contract. (An asterisk (*) in the right-hand margin indicates subcontract language or requirements throughout Parts 1, 2 and 3 of these Documents.)

SUBCONTRACTOR – A person, corporation or firm supplying labor and/or materials for work at the Site of this Project for the Contractor under a Subcontract.

SURETY – The corporate body which is bound with and for the Contractor for the performance of this contract and for the payment of all lawful indebtedness pertaining thereto.

SPECIFICATIONS – GENERAL – Refers to specifications pertinent to the performance of any City Project anticipated to exceed \$2,000, as provided in Parts 1, 2 and 3 of these Documents.

SPECIFICATIONS – TECHNICAL – Refers to those Specifications pertinent to this Project and includes information regarding materials, products, etc., as provided in PART 4 of these Documents.

SPECIFICATIONS – SPECIAL – Refers to special information items pertinent to only this Project and includes Project Description, location, measurements, maps, drawings, etc.

SPECIFICATIONS – (without particular included as above) Refers to General Specifications, Technical Specifications and/or Special Specifications outlined in this Document.

WORK ON (OR AT) THE PROJECT or PROJECT SITE – Work to be performed under this Contract at the location of this Project, including transportation of materials and supplies to or from the Site by employees of the Contractor and/or Subcontractors.

PART 1 - BIDS

SECTION 1 – INSTRUCTIONS TO BIDDERS

1.0 INSTRUCTIONS TO BIDDERS

1.0.1 BIDS

- a. Bidding documents to be submitted must remain attached within this Contract Document.
- b. All bids submitted shall be on forms provided without alterations or interlineations and shall be subject to all requirements of these Instructions to Bidders and all the forms and Documents immediately following these Instructions in Section 2, Bid Proposal.
- c. All Bid Proposals submitted for consideration shall be enclosed in a sealed envelope which is clearly labeled "Bid Documents" with the Project name and/or number, the name of Bidder, the date and time of Bid Opening written on the envelope to prevent premature opening.
- d. If unit prices are requested, the Unit Price for each of the several items in the Bidder's proposal shall include its pro rata share of overhead so that the sum of the products obtained by multiplying the quantity for each item by the unit price represents the total bid. Should conditions make it necessary to revise the quantities, a limit will then be fixed for such increased or decreased quantities. Should the net monetary value of all such changes increase or decrease the original price by more than twenty-five percent (25%) negotiated price change shall be allowed, if warranted. Any bid not conforming to this requirement may be rejected.

1.0.2 BID GUARANTY

- a. No Bid will be considered unless it is accompanied by a Bid Guaranty of not less than five percent (5%) of the amount of the Bid to ensure the execution of the Contract and the furnishing of surety bond or bonds by the successful Bidder, as required by the Contract Documents. Cash deposits will not be accepted. Negotiable U.S. Government Bonds (at par value) and certified checks or bank drafts, made payable to the **City of Muskegon**, may be used, or a bid bond in the format provided which shall be secured by a guaranty or a surety company listed in the latest issue of U.S. Treasury Circular 570, and shall be within the maximum amount specified for such company in said Circular.
- b. Revised Bids submitted before the opening of Bids, whether forwarded by mail or telegraphic communication, if representing an increase in excess of two percent (2%) of the original bid, must have the Bid Guaranty adjusted accordingly; otherwise the Bid will not be considered.
- c. The Bid Guaranty of unsuccessful Bidders, or the amount thereof, will be returned as soon as practicable after the awarding of the contract. The Bid Guaranty of any Bidder withdrawing his/her Bid in accordance with the conditions set forth in Paragraph 13 hereof will be returned promptly.
- d. When telegraphic modifications of Bids are received as provided above, Bidders are cautioned that such modifications shall make the Bid as modified or amended subject to rejection if not explicit and/or in any sense are subject to misinterpretation.

1.0.3 ALTERNATIVE BIDS

No alternative bids will be considered unless alternative bids are specifically requested.

1.0.4 INTERPRETATIONS AND/OR ADDENDA

- a. No oral interpretation will be made to any Bidder as to the meaning of the Documents or any part thereof. A request for any interpretation will be in writing to the City of Muskegon, and any such request received seven (7) or more days before the scheduled Bid Opening will be considered.
- b. Every interpretation made will be in writing in the form of an Addendum to the Contract itself and, when issued, will be on file in the City Clerk's office at least five (5) days prior to the Bid Opening for each Bidder's review.

1.0.5 BIDDER'S RESPONSIBILITIES

- a. Site Inspection. Each Bidder will assume the responsibility for visiting the site of the proposed work and for fully acquainting himself/herself with the conditions existing there relating to construction and labor, and should fully inform himself/herself as to the facilities involved, the difficulties and restrictions attending the performance of the Contract.
- b. Knowledge of Bid and Contract Documents. The Bidder is responsible for thoroughly examining and familiarizing himself/herself with the Bid and Contract Documents, any Drawings, Specifications and Addenda.
- c. Addenda to Contract Documents. All Bidders will assume the responsibility to make inquiry as to the Addenda issued, knowing that all such Addenda become part of the Contract. All Bidders shall be bound by any Addenda whether or not it was received or reviewed.
- d. Claims on Basis of Failure to Receive or Review Information. A successful Bidder, through the execution of this Contract, shall in no way be relieved of any obligation due to his/her failure to receive or examine any form or legal instrument, or due to the failure to visit the site and acquaint himself/herself with the existing conditions.
The City Commission will be justified in rejecting any claims submitted on the basis of 5.a, b, or c above.

1.0.6 EQUAL OPPORTUNITY EMPLOYMENT REQUIREMENT - The attention of Bidders is particularly called to the requirement for ensuring that employees and applicants for employment are not discriminated against because of their race, color, religion, sex or national origin, nor because the employee or applicant is a disabled or Viet Nam era veteran or otherwise handicapped, as outlined in Part 3, Section 2 of these Documents.

1.0.7 EMPLOYMENT AND PREVAILING WAGE AND SALARY REQUIREMENTS - The attention of Bidders is particularly called to the requirements covered in Part 3, Section 4 of these Documents concerning the payment of not less than the prevailing wage and salary rates specified, and in regard to the conditions of employment with respect to certain categories and classifications of employees. These rates of pay are the minimums to be paid during the life of this Contract.

The City of Muskegon requires that the Contractor must hire local trades and labor employees from the City of Muskegon, County of Muskegon and/or this SMSA (Standard Metropolitan Statistical Area) for the duration of this Project, insofar as these are available to perform the necessary work. Supervisory and/or technical staff officials are exempt from this requirement.

It is therefore the responsibility of the Bidder to inform himself/herself as to local labor conditions, labor supply, overtime compensation, health and welfare contributions, and prospective changes or adjustments of rates.

1.0.8 SUBCONTRACTORS* - Any Bidder submitting a Bid shall include a list of proposed subcontractors on the form provided in Part 1, Section 2 of these Documents.

The attention of Bidders is called to the Contractor's liability for all subcontractors as provided in the various sections and paragraphs on these Documents, generally indicated by an asterisk (*) in the right-hand margin.

1.0.9 NON-COLLUSION AFFIDAVIT

- a. Each Bidder submitting a bid for work, or any portion thereof, covered by these Documents, shall execute an Affidavit to the effect that he/she has not colluded with any other person, firm or

corporation in regard to any Bid submitted, in the same or similar format as provided in Part 1 Section 2 of these Documents.

- b. The successful Bidder shall secure an Affidavit to the same effect from any proposed subcontractor, before executing any subcontract, in the same or similar format as provided in Part 1, Section 2 of these Documents.

1.0.10 SECTION 3 CLAUSE (135.38) FOR FEDERALLY FUNDED PROJECTS

- a. The work to be performed under this contract is subject to the requirements of section 3 of the Housing and Urban Development Act of 1968, as amended, 12 U.S.C. 1701u (section 3). The purpose of section 3 is to ensure that employment and other economic opportunities generated by HUD assistance or HUD-assisted projects covered by section 3, shall, to the greatest extent feasible, be directed to low- and very low-income person, particularly persons who are recipients of HUD assistance for housing.
- b. The parties to this contract agree to comply with HUD's regulations in 24 CFR part 135, which implement section 3. As evidenced by their execution of this contract, the parties to this contract certify that they are under no contractual or other impediment that would prevent them from complying with the part 135 regulations.
- c. The contractor agrees to send to each labor organization or representative or worker with which the contractor has a collective bargaining agreement or other understanding, if any, a notice advising the labor organization or workers' representative of the contractor's commitments under this section 3 clause, and will post copies of the notice in conspicuous places at the work site where both employees and applicants for training and employment positions can see the notice. The notice shall describe the section 3 preference, shall set forth minimum number and job titles subject to hire, availability of apprenticeship and training positions, the qualifications for each of the positions; and the anticipated date the work shall begin.
- d. The contractor agrees to include the section 3 clause in every subcontract subject to compliance with regulations in 24 CFR part 135, and agrees to take appropriate action, as provided in an applicable provision of the subcontract or in the section 3 clause, upon the finding that the subcontractor will not subcontract with any subcontractor where the contractor has notice or knowledge that the subcontractor has been found in violation of the regulations in 24 CFR part 135.
- e. The contractor will certify that any vacant employment positions, including training positions, that are filled (1) after the contractor is selected but before the contract is executed, and (2) with person other than those to whom the regulations of 24 CFR part 135 require employment opportunities to be directed, were not filled to circumvent the contractor's obligations under the 24 CFR part 135.
- f. Noncompliance with HUD's regulations in 24 CFR, part 135 may result in sanctions, termination of this contract for default, and debarment or suspension from future HUD assisted contracts.
- g. With respect to work performed in connections with section 3 covered Indian housing assistance, section 7(b) of the Indian Self-Determination and Education Assistance Act (25 U.S.C. 450e) also applies to the work to be performed under this contract. Section 7(b) requires that to the greatest extent feasible (i) preference and opportunities for training and employment shall be given to Indians, and (ii) preference in the award of contracts and subcontracts shall be given to Indian organizations and Indian-owned Economic Enterprises. Parties to this contract that are subject to the provisions of section 3 and section 7(b) agree to comply with section 3 to the maximum extent feasible, but not derogation of compliance with section 7(b).

Examples:

1. Who are Section 3 residents? – Residents of public housing and low income person who live in the area in which a HUD-assisted project is located.
2. What is a Section 3 business? – A business that is owned by Section 3 residents; or employs Section 3 residents in full-time positions; or subcontracts with businesses which provide economic opportunities to low income persons. (CDBG)
3. What types of economic opportunities are available under Section 3? – a. Administrative/Management: accounting, bookkeeping, payroll, purchasing, research, word processing b. Services: appliance repair, carpet installation, catering computer/information, florists, janitorial, landscaping, manufacturing, marketing, photography, printing, transportation C. Construction: architecture, bricklaying, carpentry, cement/masonry, demolition, drywall, electrical, elevator construction, engineering, fencing, heating, iron works, machine operation, painting, plastering, plumbing, surveying, tile setting.
4. Who will award the economic opportunities? – Recipients of HUD financial assistance and their contractors and subcontractors are required to provide economic opportunities to the greatest extent feasible, consistent with existing Federal, State and local laws and regulations.
5. Who receives priority under Section 3? – a. For training and employment: persons in public and assisted housing; person in the neighborhood; participants in HUD Youthbuild programs; homeless person b. For contracting: business which fit the definition of a Section 3 business.
6. How can businesses find Section 3 residents to work for them? - By recruiting in the neighborhood and public housing developments to tell them about available training and job opportunities. Distributing flyers, posting signs, placing ads, and contacting resident organizations and local community development and employment agencies to find potential workers are a few effective ways of getting jobs and people together.
7. How can businesses & low income people find out more about Section 3? Contact the Fair Housing and Equal Opportunity representative at your nearest HUD office.
8. What if it appears an entity is not complying with Section 3?
There is a complaint process. Section 3 residents and business concerns may file complaints if they think a violation of Section 3 requirements has occurred where HUD-funded project is planned or underway. Complaints will be investigated; if appropriate, voluntary resolutions will be sought. A complaint that cannot be resolved voluntarily can result in an administrative hearing.
9. Will HUD require compliance? – Yes. HUD investigates complaints and monitors the performance of recipients and contractors. HUD examines employment and contract records for evidence of actions taken to train and employ Section 3 residents and train and employ Section 3 residents and to award contracts to Section 3 businesses.
10. How can Section 3 businesses or residents complain about a violation of Section 3 requirements?
They can file a complaint in writing to the local HUD Office or to: The Assistant Secretary for Fair Housing and Equal Opportunity, U.S. Department of Housing and Urban Development 451 Seventh Street, SW, Rm. 5100 Washington, DC 20410-2000. A written complaint should contain:
 - a. Name and address of the person filing the complaint;
 - b. Name and address of subject of complaint (HUD recipient contractor);
 - c. Description of acts or omissions in alleged violation of section 3;
 - d. Statement of corrective action sought.

1.0.11 STATEMENT OF BIDDER'S QUALIFICATIONS; ADDITIONAL INFORMATION

- a. Upon request, each Bidder shall submit a Statement of Bidder's Qualifications in accordance with the information requested in Part 1, Section 2, and, when specifically requested by the City, shall submit a detailed Financial Statement, particularly in lieu of a Performance Bond.

- b. Any Bidder shall furnish any data and information requested by the City Commission in its attempt to determine the ability of the Bidder to perform his/her obligations under the Contract.

1.0.12 TIME FOR RECEIVED BIDS - Bids received prior to the advertised hour of opening will be kept securely sealed. The official whose duty it is to open the Bids will decide when the specified time has arrived, and no Bid received thereafter will be considered.

1.0.13 WITHDRAWAL OF BIDS - Bids may be withdrawn on written or telegraphic request dispatched by the Bidder in time for delivery in the normal course of business prior to the time fixed for opening; provided that written confirmation of any telegraphic withdrawal over the signature of the Bidder is placed in the mail and post-marked prior to the time set for Bid opening.

1.0.14 OPENING OF BIDS - At the time and place fixed for the opening of Bids, the City Clerk will cause to be opened and publicly read aloud every Bid received within the time set for receiving Bids, irrespective of any irregularities therein. Bidders and other persons properly interested may be present in person or by representative.

1.0.15 AWARD OF CONTRACT - If the Contract is awarded, it will be awarded to the responsible Bidder submitting the lowest Bid complying with the conditions set forth in these Documents. The successful Bidder will be notified at the earliest possible date.

1.0.16 REJECTION OF BIDS; CITY'S RIGHTS

- a. The City Commission reserves the right to reject any and all Bids, and to waive any informality in Bids received, whenever such rejection or waiver is in its own best interest.
- b. The City Commission may consider as irregular and reject any Bid on which there is an alteration.
- c. The City Commission shall have the right to take such steps as it deems necessary to determine the ability of the Bidder to perform his/her obligations under the Contract.
- d. The right is reserved to reject any Bid where an investigation of the available evidence and/or information provided does not satisfy the City Commission of the Bidder's capacity to carry out the terms of the Contract.

1.0.17 EXECUTION OF CONTRACT AGREEMENT; PERFORMANCE AND PAYMENT BONDS

- a. Subsequent to the award and within ten (10) days after the Documents have been presented for signature, the successful Bidder shall execute the Agreement and deliver the requested number of copies to the City of Muskegon.
- b. Execution of the Agreement will require completion of the work in accordance with the Contract in its entirety.
- c. Upon delivery of the executed Contract Documents, the successful Bidder shall furnish the requisite bonds, in the penal sum not less than the amount of the Contract as awarded, as security for the faithful performance of the Contract and of the payment of all persons, firms or corporations to whom the Bidder as Contractor may become legally indebted, except as provided in paragraph (e) below.
- d. Such bonds shall be completed in accordance with the Instructions in Part 1 Section 2, and shall bear the same date as, or a date subsequent to, that of the Agreement.
The surety bond shall be signed by a guaranty or the surety company listed in the latest issue of the U.S. Treasury Circ. 570, and the penal sum shall be within the maximum specified for such company in said Circular.
- e. In cases where this Contract is \$50,000 OR LESS and the successful Bidder is unable to, or chooses not to, provide the appropriate Performance Bonds, the Bidder may submit four letters of sincere

recommendation as to his/her prior performance to the City Manager for consideration in lieu of a Performance Bond, in basically the form described in Part 2 of these Documents.

This action must be taken prior to the execution of the Contract Agreement and the four letters must be accompanied by a statement from the Bidder, which contains the minimum requirements indicated for "Statement of Bidder's Qualifications". Upon City Manager and/or City Commission acceptance of the letters in lieu of the Performance Bond, the Contract Agreement shall be so executed.

- f. Failure of the successful Bidder to execute such number of Contract Documents as requested, to supply the required bonds or letters of recommendation with the Bidder's statement, and/or to meet the prescribed time limits, shall constitute a default.
- g. Upon such default, the City Commission may either award the Contract to the next lowest responsible bidder or re-advertise for bids.

The Commission may further charge against the defaulting Bidder the difference between the amount of his/her Bid and the amount for which a Contract for the work is subsequently executed, irrespective of whether the amount then exceeds the amount of the Bid Bond.

If a more favorable bid is received by re-advertising, the defaulting Bidder shall have no claim against the City of Muskegon.

1.0.18 COMMENCEMENT NOTICE TO PROCEED – The Contractor shall commence work only upon delivery of a Notice to Proceed from the City. In the event the said notice is not delivered within ten (10) days of the date of this agreement, then the dates for completion and any other performance dates shall be adjusted without further agreement so that the performance and completion dates shall be delayed the number of days in excess of ten (10) after the execution of the contract during which the City did not deliver the notice.

1.0.19 LOCAL PREFERENCE POLICY - The City Commission may give local preference on purchases and contractors to local businesses. If a contractor or business is located within the city limits of the City of Muskegon, a bid may be accepted at or within 2% of the lowest non-local bid. A contractor or business located within the County of Muskegon, a bid may be accepted at or within 1% of the lowest non-local bid.

Any contractor electing to pay prevailing wage to its employees may be granted an additional 1% allowance, up to a maximum of 3%. Prevailing wage will be paid according to the newest wage determination published by the U.S. Federal Government and agreed upon before awarding a contract. Contractor will be required to sign an affidavit ensuring proper payment to employees.

SECTION 2 - BID PROPOSAL

1.1 CONTRACT BIDDER'S CHECKLIST

THIS FORM IS A REFERENCE TOOL FOR BIDDING CONTRACTORS

The following forms ***MUST*** be completed:

	Completed?	
	Yes	No
1. Transmittal Letter for Bid Proposal (must acknowledge addenda received)		
2. Bidder Certification and Agreement		
3. Management Plans Questionnaire		
4. Bid Proposal		
5. Bid Bond (must be 5% of total bid)		
6. Non-Collusion Affidavit of Prime Bidder		
7. List of Proposed Sub-Contractors (if applicable)		
8. Disadvantaged Contractor Affidavit (if applicable)		
9. Statement of Bidders Qualifications (if applicable)		
10. Bid Tabulation Spreadsheet(s)		

Actual Completion of All Required Forms is the **Sole Responsibility of the Bidder**

FAILURE TO COMPLETE THE NECESSARY FORMS MAY RESULT IN BID REJECTION

1.2 TRANSMITTAL LETTER FOR BID PROPOSAL

Bidder/Company Name _____

Name & Title of Head of Company _____

Street Address _____

City, State, ZIP _____

Phone Number _____

Email Address _____

Date _____

**CITY OF MUSKEGON, MICHIGAN
933 TERRACE ST.
MUSKEGON, MI 49443-0536**

Dear Awarding Agent,

Having examined the Bid Specifications and Contract Documents, including all forms and instructions, and the site of the proposed work, and being familiar with all of the conditions surrounding the construction of the proposed project, including the availability of materials and labor, and having received and reviewed the following Addenda:

For the purpose of Local Preference Policy, the contractor: (must check one)

- Will** voluntarily pay its employees Prevailing Wages
- Will **NOT** be paying Prevailing Wages

I/We hereby propose to furnish all labor, materials and supplies, and to construct the project in accordance with the Contract Documents and at the prices indicated in the attached Bid Proposal. Submitted prices are to cover all expenses incurred in performing the work required under the Contract Document, of which this letter and attached Proposal are a part.

In accordance with the Instructions to Bidders, all appropriate documents, forms, etc., have been properly completed and are attached hereto, along with the Bidder Certification and Agreement, List of Subcontractors, Non-Collusion Affidavits, and the proper Bid Guaranty.

I/We hereby respectfully submit the attached Bid Proposal for consideration by the City of Muskegon on the above-referenced Project.

Signature of Bidder/Representative

Printed Name and Title

1.3 BIDDER CERTIFICATION AND AGREEMENT

PART I.

The Undersigned hereby agrees:

That he/she has examined the Bid Specifications/Contract Documents, including specifications, forms and instructions;

That he/she has received and reviewed the following Addenda:

That he/she has examined the Site of the proposed work and is familiar with all of the conditions surrounding the construction of the proposed project and the availability of materials and labor.

PART II.

The Undersigned hereby agrees:

That he/she will enter into a contract to furnish the labor, materials, tools and construction equipment necessary for the full and complete execution of the work at and for the prices indicated in his/her official Bid Proposal, if said Proposal is accepted by the City;

That, at the time of execution of said Contract, he/she will furnish requisite bonds with such sureties (or letters of recommendation accompanied by a Bidder's Statement) for the faithful performance of the Contract, for the payment of all materials used therein, and for all labor expended thereon in accordance with the forms and instructions provided;

That he/she will construct the project in accordance with the Contract Documents within the specified time.

PART III.

The Undersigned hereby agrees:

To commence work within 10 days after the date of the "Notice of Award" from the City.

To comply with all applicable Adopted Guidelines and requirements, wage rates, labor standards, equal opportunity requirements, subcontract (or) requirements, and any other specifications indicated or referred to within these Contract Documents.

The Undersigned herewith attaches an Affidavit in proof that he/she has not entered into a collusive agreement with any person in respect to this Bid or any other bid, or the submitting of bids for the Contract for which this Bid is submitted.

The Undersigned is prepared to submit a Statement of Bidder's Qualifications, a financial statement, and/or any information requested by the City.

However, once work has commenced the project shall be completed without interruption of normal working days unless authorized in writing by the Engineer.

PART IV

In regard to non-segregated facilities, the Undersigned certifies:

That he/she does not maintain or provide for any employees any segregated facilities at any of his/her establishments;

That he/she does not permit employees to perform their services at any location, under his/her control, where segregated facilities are maintained;

That he/she will not maintain or provide for employees any segregated facilities at any of his/her establishments, and that he/she will not permit employees to perform their services at any location under his/her control where segregated facilities are maintained.

The Undersigned hereby agrees:

That a breach of this section of the Bidders Certification will be a violation of the Equal Opportunity clause in any contract resulting from acceptance of this Bid.

That he/she will obtain identical certification from proposed sub-contractors prior to the award of subcontracts exceeding \$10,000 which are not exempt from the provisions of the Equal Opportunity clause (unless already obtained for specific time periods), and that he/she will retain such certifications on file.

[As used in this section of this Bidder Certification, the term “segregated facilities” means any waiting rooms, work areas, restrooms, and washrooms, restaurants and other eating areas, time clocks, locker rooms and other storage or dressing areas, parking lots, drinking fountains, recreation or entertainment areas, transportation and housing facilities provided for employees which are segregated by explicit directive or are in fact segregated on the basis of race, color, religion or national origin, because of habit, local custom, or otherwise.]

NOTE: The penalty for making false statements in offers is prescribed in 18 U.S.C. 1001.

SIGNED: _____ DATED: _____

(Printed name)

(Title)

(Company/Bidder)

(Company/Bidder Street Address)

(Company/Bidder City, State Zip)

1.4 BID BOND

KNOW ALL MEN BY THESE PRESENTS, that we the undersigned,

_____ as PRINCIPAL, and
(Name of Principal)

_____ as SURETY are held
(Name of Surety)

and firmly bound unto the City of Muskegon, Michigan, in the penal sum of _____

_____ dollars, (\$ _____) lawful money of the United States, for the payment of which sum well and truly to be made, we bind ourselves, our heirs, executors, administrators, successors, and assigns, jointly and severally, firmly by these presents.

THE CONDITION OF THIS OBLIGATION IS SUCH, that whereas the Principal has submitted the Accompanying Bid, dated _____, 20_____, for _____.

NOW, THEREFORE, if the Principal shall not withdraw said Bid within the period specified for withdrawal; and shall within ten (10) days after the prescribed forms are presented for signature enter into a written Contract with the City of Muskegon in accordance with the Bid as accepted, and give bond with good and sufficient surety or sureties, as may be required for the faithful performance and proper fulfillment of such Contract; or

In the event of the withdrawal of said Bid within the period specified for withdrawal, or the failure to enter into such contract and give such bond within the time specified; and if the Principal shall pay the City of Muskegon the difference between the amount specified in said Bid and the amount for which the City of Muskegon may procure the required work or supplies or both, if the latter be in excess of the former.

THEN the above obligation shall be void and of no effect; otherwise shall remain in full force and virtue

IN WITNESS WHEREOF, the above-bounded parties have executed this instrument

Under their several seals this _____ day of _____, 20____ the name and corporate seal of each corporate party being hereto affixed and these presents signed by its undersigned representative, pursuant to authority of its governing body.

In presence of

_____ (SEAL)
(Individual Principal)

(Business Address including Zip Code)

(Partnership)

(Business Address including Zip Code)

Attest:

By:

(SEAL)

(Corporate Principal)

(Business Address including Zip Code)

Attest:

Affix
Corporate
Seal

Countersigned

By

Attorney-in-fact, State of _____

CERTIFICATE AS TO CORPORATE PRINCIPAL

I, _____, certify that I am the _____,

Secretary of the Corporation named as Principal in the within Bond; that

_____, who signed the said Bond on behalf of the Principal was then

_____ of said Corporation; that I know his/her signature, and his/her signature thereto is genuine; and that said bond was duly signed, sealed, and attested to for and in behalf of said Corporation by authority of this governing body.

Affix
Corporate
Seal

By: _____

Title: _____

1.6 LIST OF PROPOSED SUB-CONTRACTORS

To be submitted by each Bidder with Bid Proposal in accordance with Para. 8, Part 1, Section 1. Before a subcontract is executed by the successful Bidder, the subcontractor must be approved by the City of Muskegon and the required documents executed in accordance with the Contract Documents.

1.	NAME OF FIRM	_____
	FIRM ADDRESS	_____

2.	NAME OF FIRM	_____
	FIRM ADDRESS	_____

3.	NAME OF FIRM	_____
	FIRM ADDRESS	_____

4.	NAME OF FIRM	_____
	FIRM ADDRESS	_____

5.	NAME OF FIRM	_____
	FIRM ADDRESS	_____

6.	NAME OF FIRM	_____
	FIRM ADDRESS	_____

7.	NAME OF FIRM	_____
	FIRM ADDRESS	_____

1.7 DISADVANTAGED CONTRACTOR AFFIDAVIT

Please provide the name(s) of all Disadvantaged subcontractors from whom you solicited bids for this project and additional information below.

Disadvantaged Contractor:	Contact Person:	Contact Method/Date:	Decision (Yes or No):
1. _____	_____	_____	_____
2. _____	_____	_____	_____
3. _____	_____	_____	_____
4. _____	_____	_____	_____

Of the Disadvantaged Contractors listed above, please indicate why they will not be used on this project.

Disadvantage Contractor:	Decision/Reason:
1. _____	_____ _____ _____
2. _____	_____ _____ _____
3. _____	_____ _____ _____
4. _____	_____ _____ _____

1.8 STATEMENT OF BIDDER'S QUALIFICATIONS

To be submitted by the Bidder upon specific request of City of Muskegon unless in connection with Letters of Recommendation in lieu of Performance Bond as provided in Section 1. The Statement of Bidder's Qualifications as follows must accompany the four Letters.

1.8.1 SUMMARY OF BIDDER'S INFORMATION TO BE PROVIDED

Each of the following items must be responded to in writing, and the information provided thereby must be clear and understandable. Upon completion, the Statement must be signed by the Bidder in front of a Notary Public and notarized. The Bidder may supply such additional information as desired after responding to each of these items:

1. NAME OF BIDDER (Company, individual, etc.)
2. PERMANENT MAIN OFFICE ADDRESS OF BUSINESS INCLUDING ZIP CODE.
3. DATE BUSINESS WAS ESTABLISHED.
4. IF A CORPORATION, WHERE WAS IT INCORPORATED?
5. NUMBER OF YEARS ENGAGED IN CONTRACTING BUSINESS UNDER PRESENT NAME?
FIRM OR TRADE NAME? UNDER A PREVIOUS NAME?
6. SCHEDULE OF OUTSTANDING CONTRACTS, showing amount of each contract and the anticipated completion date of each.
7. GENERAL CHARACTER OF WORK PERFORMED BY YOUR COMPANY.
8. HAS THIS COMPANY EVER FAILED TO COMPLETE ANY WORK AWARDED IT?
If so, WHERE AND WHY?
9. HAS THIS COMPANY EVER DEFAULTED ON A CONTRACT?
If so, WHERE ANY WHY?
10. LIST THE PROJECTS RECENTLY COMPLETED BY YOUR COMPANY, stating approximate cost of each and the month/year completed. Indicate which, if any, have provided your company with a Letter of Recommendation.
11. INDICATE EXPERIENCE IN CONSTRUCTION WORK SIMILAR TO THIS PROJECT.
12. LIST YOUR MAJOR EQUIPMENT AVAILABLE FOR THIS CONTRACT.
13. INDICATE BACKGROUND AND EXPERIENCE OF THE PRINCIPAL MEMBERS OF YOUR ORGANIZATION, INCLUDING OFFICERS.
14. INDICATE CREDIT AVAILABLE TO YOUR COMPANY.
15. LIST BANK REFERENCES. If a detailed financial statement is available attach it to this statement.

16. ARE YOU WILLING TO COMPLETE A DETAILED FINANCIAL STATEMENT AND FURNISH ANY OTHER INFORMATION REQUIRED AND REQUESTED BY THE CITY OF MUSKEGON?

17. INCLUDE THE FOLLOWING STATEMENT: “The undersigned hereby authorizes and requests any person, firm or corporation to furnish any information requested by the City of Muskegon in verification of the recitals comprising this Statement of Bidder’s Qualifications.”

18. INCLUDE THE FOLLOWING AT THE END OF YOUR STATEMENT:

Dated this _____ day of _____, 20____.

COMPANY/BIDDER NAME

SIGNATURE

PRINTED NAME AND TITLE OF PERSON SIGNING

19. INCLUDE OFFICIAL NAME AND DATA FOR NOTARY PUBLIC TO NOTARIZE DOCUMENT.

1.9 DBE/MBE/WBE PROCUREMENT POLICY

1.9.1 POLICY STATEMENT: 2014-31 (e)

It is the policy of the City of Muskegon to assure that small disadvantaged business enterprises (DBE), minority business enterprises (MBE), and woman-owned business enterprises (WBE) are given the opportunity to participate in contracting and procurement for supplies, construction, equipment and services under federal contracts and collaborations.

This policy applies to all contracts/procurement for supplies, construction equipment and services under any federally contracted grant or cooperative agreement. The purpose is to ensure nondiscrimination in the solicitation, either by competitive bidding or negotiation, and award and administration of federally assisted contracts and collaborations.

Entities contracting or sub-contracting with the City of Muskegon shall comply with regulations relative to nondiscrimination in Federally-assisted programs as amended from time to time (hereinafter referred to as the Regulations), which are herein incorporated by reference and made a part of this contract.

During the performance of any contract, the contractor, for itself, its assignees and successors in interest (hereinafter referred to as the “contractor”) agrees, as follows:

1.9.2 STATEMENT OF NON-DISCRIMINATION

The contractor, with regard to the work performed by it during the contract, shall not discriminate on the grounds of race, color, sex, or national origin in the selection, retention, and treatment of subcontractors, including procurements of supplies, construction, equipment and services.

1.9.3 FAIR SHARE GOALS

All methods of solicitation shall include the following language to meet “Good Faith Effort” requirements as stated in the general provisions of EPA’s 40 CFR 33 of the Federal Regulation:

This contract is subject to the Environmental Protection Agency’s (EPA) “fair share policy,” which includes EPA-approved “fair share goals” for Disadvantaged Business Enterprise (DBE), Minority Business Enterprise (MBE) and Woman Business Enterprise (WBE) firms in the Construction, Supplies, Equipment, and Services procurement categories. EPA’s policy requires that applicants and prime contractors make a good faith effort to award a fair share of contracts, subcontracts and procurements to Minority Business Enterprise and Women-Owned Business Enterprise firms. Although EPA’s policy does not mandate that the fair share goals be achieved, it does require applicants and prime contractors to demonstrate use of the six affirmative steps, and adhere to the current fair share goals for the State of Michigan.

1.9.4 GOOD FAITH EFFORTS

(1) The City of Muskegon shall ensure DBE/MBE/WBEs are made aware of contracting opportunities to the fullest extent practicable through outreach and recruitment activities by maintaining a solicitation list of DBE/MBE/WBE businesses and notifying them whenever they are potential sources.

(a) Maintain and update a listing of qualified DBE/MBE/WBEs that can be solicited for construction, equipment, services and/or supplies on the City of Muskegon website.

(b) Provide listings to all interested parties who request copies of the bidding or proposing documents.

(c) Contact appropriate sources within our geographic area to identify DBE/MBE/WBEs for placement on our business listings.

(d) Utilize other DBE/MBE/WBE listings such as those of the States Minority Business Office, the Small Business Administration, Minority Business Development Agency (MBDA) of the Department of Commerce, EPA OSDBU, DOJ, HUD, DOT and Department of Homeland Security.

(e) Solicitation lists are available for review at all times via the city website.

(2) The City of Muskegon shall make information of forthcoming opportunities available to DBE/MBE/WBEs and arrange time for viewing of contracts and establish delivery schedules, where requirements permit, in a way that encourages and facilitates participation by DBEs, MBEs, and WBEs in the competitive process. This includes, whenever possible, posting solicitations for bids or proposals for a minimum of 30 calendar days(federal projects) and 10 calendar days(local projects), before the bid or proposal closing date.

(a) Develop realistic delivery schedules which may provide for greater DBE/MBE/WBE participation.

(b) Advertise through the minority media in order to facilitate DBE/MBE/WBE utilization. Such advertisements may include, but are not limited to, contracting and subcontracting opportunities, hiring and employment, or any other matter related to the project.

(c) Advertise in general circulation publications, trade publications, State agency publications and minority and women's business focused media concerning contracting opportunities on our projects. Maintain a list of minority and/or women's business-focused publications that may be utilized to solicit DBE/MBE/WBEs.

(3) The City of Muskegon will consider in the contracting process whether firms competing for large contracts could subcontract with DBE/MBE/WBEs. The City of Muskegon will divide total requirements when economically feasible and practical into smaller tasks or quantities in order to increase opportunities for participation by DBE/MBE/WBEs in the competitive process.

(a) Perform an analysis to identify portions of work that can be divided and performed by qualified DBE/MBE/WBEs.

(b) Scrutinize the elements of the total project to develop economical units of work that are within the bonding range of DBE/MBE/WBEs.

(c) Conduct meetings, conferences, and follow-ups with DBE/MBE/WBE associations and minority media to inform these groups of opportunities to provide construction, equipment, services and supplies.

(4) The City of Muskegon will consider and encourage contracting with a consortium of DBE/MBE/WBEs when a contract is too large for one of these firms to handle individually.

(a) Notify DBE/MBE/WBEs of future procurement opportunities so they may establish bidding solicitations and procurement plans.

(b) Provide DBE/MBE/WBEs trade organizations with succinct summaries of solicitations.

(c) Provide interested DBE/MBE/WBEs with adequate information about plans, specifications, timing and other requirements of the proposed projects.

(5) Use the services and assistance of the Small Business Administration (SBA) and the Minority Business Development Agency (MBDA).

(a) Use the services of outreach programs sponsored by the MBDA and/or the SBA to recruit bona fide firms for placement on DBE/MBE/WBE bidder's lists to assist these firms in the development of bid packaging.

(b) Seek out Minority Business Development Centers (MBDCs) to assist recipients and prime contractors in identifying DBE/MBE/WBEs for potential work opportunities on projects

(6) If the prime contractor awards subcontractors, the prime contractor is required to take the steps in subparagraphs (1)-(5) of this section.

1.9.5 DOCUMENTATION/REPORTING

The contractor shall provide all information and reports required by the Regulations, or directives issues pursuant thereto, and shall permit access to its books, records, accounts, other sources of information, and its facilities as may be determined by the appropriate federal agency to be pertinent to ascertain compliance with such Regulations or directives. Where any information required of a contractor is in the exclusive possession of another who fails or refuses to furnish this information, the contractor shall so certify to the appropriate State or Federal Agency, as appropriate, and shall set forth what efforts it has made to obtain the information.

1.9.6 NON – COMPLIANCE

Contractors, sub-contractors, and other associated entities failing to comply with the federal regulations legally required under contracts associated with Environmental Protection Agency (EPA), Housing and Urban Development (HUD), Department of Justice (DOJ), Department Of Transportation (DOT), or Department of Homeland Security (DHS) that have been granted to the City of Muskegon, may result in delayed closings, withholding the release of funds, or commitment cancellation.

1.10 BID TABULATION SPREADSHEETS

The Bid Tabulation spreadsheet(s) in these contract documents were created in Excel. Any Contractor who would like to use this spreadsheet in preparing a bid may obtain an electronic copy from the Engineering Office by calling the Engineering Department at (231)-724-6707.

1.10 BID TABULATION

City of Muskegon
Engineering Department

Project Engineer: KP
Project Number: H92341
Project description: New St
Engineer's Estimate: \$1,129,433.56

Date: 5/2/2024

Line Item	Pay Code	Description	Units	Quantity	Unit Price	Total
1	1100001	Mobilization, Max \$100,000	LSUM	1		
2	2040020	Curb and Gutter, Rem	Ft	322		
3	2040055	Sidewalk, Rem	Syd	817		
4	2057002	Machine Grading, Modified	Sta	21.6		
5	2080020	Erosion Control, Inlet Protection, Fabric Drop	Ea	17		
6	3020020	Aggregate Base, 8 inch	Syd	6967		
7	3060005	Aggregate Surface Cse	Cyd	30		
8	3062001	Driveway Maintenance, Residential	Ea	32		
9	3062002	Intersection Maintenance	Ea	9		
10	4020600	Sewer, Cl E, 12 inch, Tr Det B	Ft	1851		
11	4027001	Sewer, Ductile Iron Class 52, 12 inch, Tr Det B	Ft	96		
12	4030004	Dr Structure Cover, Adj, Case 1, Modified	Ea	9		
13	4030010	Dr Structure Cover, Type B	Ea	15		
14	4030025	Dr Structure Cover, Type D	Ea	1		
15	4030050	Dr Structure Cover, Type K	Ea	17		
16	4030210	Dr Structure, 48 inch dia	Ea	9		
17	4030312	Dr Structure, Tap, 12 inch	Ea	2		
18	4037001	Dr Structure Cover, Adj, Add Depth, Modified	Ft	2		
PAGE 1 TOTAL						

City of Muskegon
Engineering Department

Project Engineer: KP
Project Number: H92341
Project description: New St
Engineer's Estimate: \$1,129,433.56

Date: 5/2/2024

Line Item	Pay Code	Description	Units	Quantity	Unit Price	Total
19	4037050	Catch Basin, 2 Ft Dia, Special Detail	Ea	14		
20	4037050	Catch Basin, 4 Ft Dia, Special Detail	Ea	2		
21	5010005	HMA Surface, Rem	Syd	5543		
22	5012025	HMA, 4EML	Ton	1518		
23	8010007	Driveway, Nonreinf Conc, 8 inch	Syd	753		
24	8020038	Curb and Gutter, Conc, Det F4, Modified	Ft	4408		
25	8030010	Detectable Warning Surface	Ft	24		
26	8030044	Sidewalk, Conc, 4 inch	Sft	154		
27	8030048	Sidewalk, Conc, 8 inch	Sft	10		
28	8032003	Curb Ramp, Conc, 7 inch	Sft	152		
29	8070095	Post, Mailbox	Ea	12		
30	8120012	Barricade, Type III, High Intensity, Double Sided, Lighted, Furn	Ea	4		
31	8120013	Barricade, Type III, High Intensity, Double Sided, Lighted, Oper	Ea	4		
32	8120170	Minor Traf Devices, Modified	LSUM	1		
33	8120252	Plastic Drum, Fluorescent, Furn	Ea	100		
34	8120253	Plastic Drum, Fluorescent, Oper	Ea	100		
35	8120350	Sign, Type B, Temp, Prismatic, Furn	Sft	276		
36	8120351	Sign, Type B, Temp, Prismatic, Oper	Sft	276		
37	8120352	Sign, Type B, Temp, Prismatic, Spec, Furn	Sft	20		
38	8120353	Sign, Type B, Temp, Prismatic, Spec, Oper	Sft	20		
					PAGE 2 TOTAL	

City of Muskegon
Engineering Department

Project Engineer: FP Date: 4/24/2024
 Project Number: H92342
 Project description: 2nd St; Houston to Muskegon
 Engineer's Estimate: \$302,647.00

Line Item	Pay Code	Description	Units	Quantity	Unit Price	Total
19	4037050	Dr Structure Cover, Type K, Modified	Ea	3		
20	5012025	HMA, 4EML	Ton	304		
21	8017011	Driveway, Nonreinf Conc, 6 Inch, Modified	Syd	106		
22	8017011	Driveway, Nonreinf Conc, 8 Inch, Modified	Syd	32		
23	8020038	Curb and Gutter, Conc, Det F4, Modified	Ft	1002		
24	8020050	Driveway Opening, Conc, Det M	Ft	39		
25	8030010	Detectable Warning Surface	Ft	98		
26	8030030	Curb Ramp Opening, Conc	Ft	127		
27	8030044	Sidewalk, Conc, 4 inch	Sft	3137		
28	8030046	Sidewalk, Conc, 6 inch	Sft	349		
29	8032002	Curb Ramp, Conc, 6 inch	Sft	662		
30	8110024	Pavt Mrkg, Ovly Cold Plastic, 6 inch, Crosswalk	Ft	273		
31	8110044	Pavt Mrkg, Ovly Cold Plastic, 18 inch, Stop Bar	Ft	36		
32	8120012	Barricade, Type III, High Intensity, Double Sided, Lighted, Furn	Ea	6		
33	8120013	Barricade, Type III, High Intensity, Double Sided, Lighted, Oper	Ea	6		
34	8120026	Pedestrian Type II Barricade, Temp	Ea	12		
35	8120100	Dust Palliative, Applied	Ton	25		
36	8120170	Minor Traf Devices	LSUM	1		
37	8120252	Plastic Drum, Fluorescent, Furn	Ea	24		
38	8120253	Plastic Drum, Fluorescent, Oper	Ea	24		
					PAGE 2 TOTAL	

City of Muskegon Engineering Department	Project Engineer:	FP	Date:	4/24/2024
	Project Number:	H92342		
	Project description:	2nd St; Houston to Muskegon		
	Engineer's Estimate:	<input type="text" value="\$302,647.00"/>		

Line Item	Pay Code	Description	Units	Quantity	Unit Price	Total
39	8120350	Sign, Type B, Temp, Prismatic, Furn	Sft	434		
40	8120351	Sign, Type B, Temp, Prismatic, Oper	Sft	434		
41	8120352	Sign, Type B, Temp, Prismatic, Spec, Furn	Sft	64		
42	8120353	Sign, Type B, Temp, Prismatic, Spec, Oper	Sft	64		
43	8160062	Topsoil Surface, Furn, 4 inch	Syd	603		
44	8167011	Hydroseeding	Syd	603		
45	8237001	Water Service, 1 inch, Copper Type K	Ft	130		
46	8237001	Water Service, Private Property, 1 inch	Ft	108		
47	8237050	Corporation Stop, 1 inch	Ea	7		
48	8237050	Curb Stop and Box, 1 inch	Ea	5		
49	8237050	Meter Pit Complete	Ea	2		
50	8237050	Water Service, Building Connection, 1 Inch	Ea	7		
51	8237050	Water Valve Box and Cover, Complete	Ea	2		
52	8240030	Electronic Model Revision	Hr	10		
PAGE 3 TOTAL						

2nd St BID:

New St BID:

TOTAL BID:

PART 2 - AGREEMENT

2.0 AWARDEE CHECKLIST

THIS FORM IS A REFERENCE TOOL FOR AWARDEE CONTRACTORS

The following forms **MUST** be completed:

	Completed?	
	Yes	No
1. Agreement (three signed copies)		
2. Performance Bond (three signed copies)		
3. Labor & Materialman's Bond (three signed copies)		
4. Non-Collusion Affidavit of Sub-Contractor (if applicable)		
5. Letters of Recommendation (if applicable)		
6. Certificate of Insurance (see requirements in section 3.0.24)		

Actual Completion of All Required Forms is the **Sole Responsibility of the Bidder**

IMPORTANT: Please return three (3) original signed copies of each signed form

2.1 DIRECTIONS FOR PREPARATION

1. Individual sureties, partnerships, or corporations not in the surety business will not be acceptable.
2. The name of the Principal shall be shown exactly as it appears in the Contract.
3. The penal sum shall not be less than that required by the Specifications.
4. If the Principals are partners, or joint ventures, each member shall execute the bond as an individual, with his/her place of residence shown.
5. If the Principal is a corporation, the bond shall be executed under its corporate seal. If the corporation has no corporate seal, the fact shall be stated, in which case a scroll or adhesive seal shall be affixed following the corporate name.
6. The official character and authority of the person(s) executing the bond for the Principal, if a corporation, shall be certified by the Secretary or Assistant Secretary thereof under the corporate seal; OR
There may be attached copies of such corporation records as will evidence the official character and authority of the officer signing, duly certified by the Secretary or Assistant Secretary of the corporation, under the corporate seal, to be true copies.
7. The current Power-of-Attorney of the person signing for the surety company must be attached to the bond.
8. The date of the bond **MUST NOT BE PRIOR TO THE DATE OF THE CONTRACT.**
9. The following information must be placed on the bond by the surety company:
 - a. The rate of premium in dollars per thousand; and
 - b. The total dollar amount of the premium charged.
10. The signature of a witness shall appear in the appropriate place, attesting to the signature of each party to the bond.
11. Type or print the name underneath EACH SIGNATURE appearing on the bond.
12. An executed copy of the bond must be attached to each copy of the Contract (original counterpart) intended for signing.

2.2 AGREEMENT

THIS AGREEMENT, made this _____ day of _____, 20____ * by the City of Muskegon

And between _____

{a corporation organized and existing under the laws of the state of MICHIGAN};

or [a partnership consisting of _____];

or [an individual trading as _____];

Hereinafter called the “Contractor”, and the CITY OF MUSKEGON, MICHIGAN:

WITNESSETH, that the Contractor and the City of Muskegon, for the consideration stated herein, mutually agree as follows:

ARTICLE 1. Statement of Work. The Contractor shall furnish all supervision, technical personnel, labor, materials, machinery, tools, equipment, and services, including utility and transportation services, and perform and complete all work required for the construction of the improvements embraced in this Contract, NAMELY:

<<<project description>>>

and required supplemental work for the completion of this Project, all in strict accordance with the Contract, including all Addenda.

ARTICLE 2. The Contract Price. The City of Muskegon will pay the Contractor for the performance of this Contract and the completion of the work covered therein an amount in current funds not to exceed \$ _____.

ARTICLE 3. Contract. The executed contract shall consist of, but not be limited to, the following:

Invitation for Bids

Part 1- Bids

Section 1 – Instruction to Bidders

Section 2 – Bid Proposal

Part 2 – Agreement

Part 3 – General Specifications

Section 1 – Project Performance

Section 2 – Affirmative Action

Section 3 – Labor Standards/EEOC/Anti-Kickback Act

Part 4 – Engineering Specifications

Part 5 – Project Special Specifications

Part 6 – MDOT Specifications

Part 7 – Appendices

This Agreement, together with other documents enumerated in this Article 3, which said other documents are as fully part of the Contract as if attached hereto or repeated herein, form the Contract between the parties hereto.

In the event any provision in any component part of this Contract conflicts with any provision of any other component part, the Contractor shall contact the City immediately in writing for a determination, interpretation and/or clarification of conflicting parts and priority of same. Said determination from the City shall be in writing and shall become an Addendum to this Contract

**Date contract awarded by the City Commission*

IN WITNESS WHEREOF, the parties hereto have caused this AGREEMENT to be executed in
SIGNED, SEALED AND DELIVERED IN THREE (3) ORIGINAL COUNTERPARTS

ATTEST:

CONTRACTOR

Signature

Signature

Printed Name and Title

ATTEST:

CITY OF MUSKEGON

Signature

Mayor Signature

City Clerk Signature

(SEAL)

CERTIFICATION (if applicable)

I, _____, certify that I am the _____ of the Corporation
named as the Contractor herein;

That _____, who signed this Agreement on behalf of the Contractor, was then
_____ of said Corporation;

That said Agreement was duly signed for and in behalf of said Corporation by authority of its governing body, and is
within the scope of its corporate powers.

Signature

(CORPORATE SEAL)

Printed Name and Title

2.3 PERFORMANCE BOND

KNOW ALL MEN BY THESE PRESENTS, that we, _____

as Principal, and _____,
as Surety, are held and firmly bound unto the City of Muskegon, its certain attorney, successors or assigns
(hereinafter called the Obligee), in the full and just sum of _____
_____ dollars (\$) _____) lawful money
of the United States, for the payment of which sum well and truly to be made, we bind ourselves, our heirs,
administrators, executors, successors and assigns, jointly and severally, firmly by these presents:

WHEREAS, said Principal has entered into a certain contract with Obligee,
Dated _____, 20____, (hereinafter called the Contract) for: _____

and the specifications for said work shall be deemed a part hereof as fully as if set out herein:

NOW, THEREFORE, THE CONDITIONS OF THIS OBLIGATION ARE SUCH THAT:

- (a) If the Principal shall faithfully perform the Contract on his/her part, as of the time and in the manner therein provided; shall satisfy all claims and demands incurred in or for the same, or growing out of the same, or for injury or damages to persons or property in the performance thereof; shall fully indemnify and save harmless said Obligee from any and all cost and damage which the Obligee may suffer by reason of the Principal's failure to do so; and shall fully reimburse and par the Obligee any and all outlay and expense which it may occur by reason of such default; and
- (b) If, after completion and acceptance of the work by the Obligee, the Principal shall promptly remedy any defects in the work due to faulty materials or workmanship which shall appear within the period of one year from the date of completion and final acceptance of the work, and pay for any damage to said Obligee, to the State of Michigan, or to any municipal subdivision or local authority thereof to which the rights and privileges of said Obligee have passed or been assigned, then this obligation shall be null and void; otherwise it shall remain in full force and virtue.

The said Surety, for value received, hereby stipulates and agrees that no change, extension of time, alteration or addition to the terms of the Contract to the work to be performed thereunder, or to the specifications accompanying the same, shall in any wise affect its obligations on this Bond; and it does thereby waive notice of any such change, extension of time, alteration or addition to the terms of the Contract, or to the work or specifications.

It is hereby further stipulated and agreed that, if the Principal is a non-Michigan Corporation, neither the Principal nor the Surety shall be discharged from liability on this Bond, nor the bond surrendered, until such Principal files with the Obligee a certificate from the Michigan Department of Revenue evidencing the payment in full of all taxes, penalties and/or interest, and a certificate from the Unemployment Compensation Commission evidencing the payment of all unemployment compensation contributions, penalties and/or interest, due the State of Michigan from said Principal, or any non-Michigan corporation, subcontractor thereunder, or for which liability has accrued but the time for payment has not arrived.

SIGNED, SEALED AND DELIVERED IN THREE (3) ORIGINAL COUNTERPARTS

THIS _____ DAY OF _____, 20 _____.

Individual Principals Sign Here:

In the Presence of:

(SEAL)

(SEAL)

(SEAL)

Corporate Principals Sign Here:

Attest:

(Printed Name and Title)

(Printed Name)

Surety Sign Here:

Attest:

(Printed Name and Title)

(Printed Name)

SEAL

The rate of premium charge is \$ _____ per thousand.

The total amount of premium charged is \$ _____
(to be filled in by the Corporate Surety)

2.4 LABOR & MATERIALMAN'S BOND

KNOW ALL MEN BY THESE PRESENTS, that we, _____

as Principal, and _____,

as Surety, are held and firmly bound unto the City of Muskegon, its certain attorney, successors or assigns (hereinafter called the Obligee) in the penal sum of _____ dollars (\$ _____) lawful money of the United States, for the payment of which sum well and truly to be made, we bind ourselves, our heirs, personal representatives, successors and assigns, jointly and severally, firmly by these presents:

WHEREAS, said Principal has entered into a certain contract with said Obligee, dated _____, 20____, (hereinafter called the Contract) for: _____

and the specifications for said work shall be deemed a part hereof as fully as if set out herein:

NOW, THEREFORE, THE CONDITION OF THIS OBLIGATION IS SUCH that, if said Principal, all subcontractors to whom any portion of the work provided for in said Contract is sublet, and all assignees of said Principal and of such subcontractors, shall promptly make payment for all material furnished, labor supplied or performed, rental for equipment employed and services rendered by public utilities in or in connection with the prosecution of the work, whether or not said material, labor, equipment or services entered into become component parts of the work or improvement contemplated in said Contract, in any amendment, extension of, or addition to said Contract, then the above obligation shall be void; otherwise, it shall remain in full force and effect; PROVIDED, HOWEVER, that this Bond is subject to the following conditions and limitations:

- (a) All persons who have performed labor, rendered services or furnished materials or equipment, shall have a direct right of action against the Principal and Surety on this Bond, which right of action shall be asserted in proceedings instituted in the State in which such labor was performed, services rendered or materials furnished (or where labor has been performed, services rendered or materials furnished under said Contract in more than one state, then in any such states). Insofar as permitted by the laws of such State, such right of action shall be asserted in a proceeding instituted in the name of the Obligee to the use and benefit of the persons instituting such action and any or all other persons having claims hereunder; and any other person having a claim hereunder shall have the right to be made a party to such proceedings, but not later than one year after the complete performance of said Contract and final settlement thereof, and to have such claim adjudicated in such action and judgment rendered thereon; PROVIDED HOWEVER, that the Obligee shall not be liable for the payment of any costs or expenses of any such suit.
- (b) The Surety shall not be liable hereunder for any damages or compensation recoverable under any workmen's compensation or employer's liability statute.
- (c) In no event shall the Surety be liable for a greater sum than the penalty of this Bond, or subject to any suit, action or proceeding thereon, that is instituted later than one year after the complete performance of said Contract and final settlement thereof.
- (d) As used herein: The term "Person" refers to any individual, firm or corporation which has furnished materials, equipment or public utility services to be used on or incorporated in the work, or the prosecution thereof, provided for in said Contract or any amendment, extension of, or addition to said Contract; and/or to any person engaged in the prosecution of the work provided for in said

Contract or any, extensions of, or addition to said Contract, who is an agent, servant or employee of the Principal or of any subcontractor, or any assignee of said Principal or any subcontractor; and also anyone so engaged who performs the work of a laborer or mechanic, regardless of any contractual relationship between the Principal or any subcontractor, or any assignee of said Principal or subcontractor and such laborer or mechanic; BUT shall not include office employees not regularly stationed at the site of the work.

- (e) It is hereby further stipulated and agreed that, if the Principal is a non-Michigan corporation, neither the Principal nor the Surety shall be discharged from liability on this Bond, nor the Bond surrendered, until such Principal files with the Obligea a certificate from the Michigan Department of Revenue evidencing the payment in full of all taxes, penalties and/or interest due the State of Michigan from the Principal, or any non-Michigan corporation, subcontractor thereunder, or for which liability has accrued but the time for payment has not arrived.

The Surety, for value received, hereby stipulates and agrees that no change, extension of time, alteration or addition to the terms of the Contract, to the work to be performed thereunder, or to the specifications accompanying the same, shall in any wise affect the obligations of this Bond, and it does hereby waive notice of any such change, extension of time, alteration or addition to the terms of the Contract, the work thereunder, or the specifications.

SIGNED, SEALED AND DELIVERED IN THREE (3) ORIGINAL COUNTERPARTS

THIS _____ DAY OF _____, 20 ____.

Individual Principals Sign Here:

In the Presence of:

(Printed Name and Address)

(Printed Name and Address)

(Printed Name and Address)

Corporate Principals Sign Here:

Attest:

(Printed Name and Title)

(Printed Name)

Surety Sign Here:

Attest:

(Printed Name and Title)

(Printed Name)

SEAL

2.6 LETTERS OF RECOMMENDATION IN LIEU OF PERFORMANCE BOND

In accordance with Section 1, four letters of sincere recommendation may be presented to the City Manager in lieu of a performance bond when this Contract is under the amount of \$50,000 and the successful Bidder cannot produce the appropriate performance bond.

To use letters of recommendation for this purpose, your intention to do so must be disclosed as part of your bid, so that a decision on acceptability can be made prior to the contract award.

The four letters are to be presented prior to the execution of the Contract Agreement and must be accompanied by the Statement of Bidder's Qualifications as outlined (Part 1, Section 2, Bid Proposal). Each of the four letters should contain no less than the following information:

<p>THE LETTER OF RECOMMENDATION PACKAGE IS SUBJECT TO CITY MANAGER AND/OR CITY COMMISSION APPROVAL PRIOR TO LETTING THE BID OR EXECUTING THE AGREEMENT.</p>

SUMMARY OF INFORMATION TO BE INCLUDED IN EACH LETTER OF RECOMMENDATION

1. On letterhead of the recommending company, including name, address and phone number of the recommending company.
2. Include reference to the name of the company being recommended.
3. Include a brief description of the type of each of the projects the recommended company performed, the total dollars contracted for each, and the date of construction start and completion under each contract.
4. Include a statement indicating how the company being recommended performed the work involved under the contracts, whether the recommended company accomplished the work satisfactorily and within the appropriate time limits of the contracts.
5. Indicate if there was any default on the part of or litigation as a result of the recommended company.
6. Indicate if, to the best of knowledge, all subcontractors and/or suppliers of labor or materials on each project were properly compensated by the company being recommended.
7. Include a statement the same as, or similar to the following:

"I, on behalf of my organization (or company by name) recommend this company (or the name of the company being recommended) as responsible and competent, and I believe they can capably perform construction work similar to that described in this letter in a timely and satisfactory manner."

PART 3 – GENERAL SPECIFICATIONS

SECTION 1

GENERAL SPECIFICATIONS
3.0 FOR PROJECT PERFORMANCE

3.0.1 ASSIGNMENT OR NOVATION

- a. The Contractor shall not assign or transfer, whether by an assignment or novation, any of its rights, duties, benefits, obligations, liabilities or responsibilities under this Contract without the written consent of the City of Muskegon; provided, however, that assignments to banks, trust companies or other financial institutions may be made without said consent.
- b. No assignment or novation of this Contract shall be valid unless it expressly provides that the assignment of any of the Contractor's rights or benefits under the Contract is subject to a prior lien for labor performed, services rendered, and materials, tools and equipment supplied for the performance of the work under this Contract in favor of all persons, firms or corporations rendering such labor or services, or supplying such materials, tools or equipment.

3.0.2 CONFLICT OF INTEREST

- a. No official of the City of Muskegon who is authorized in such capacity and on behalf of the City to negotiate, make, accept or approve, or to take part in negotiating, making, accepting or approving, any engineering, inspection, construction or material supply contract, or any subcontract, in connection with the construction of this Project shall become directly or indirectly interested personally in this Contract or in any part hereof.
- b. No officer, employee, architect, attorney, engineer or inspector of or for the City who is authorized in such capacity, and on behalf of the City, to exercise any legislative, executive, supervisory or other similar function in connection with the construction of this Project, shall become directly or indirectly interested personally in this Contract or in any part hereof, any material supply contract, any subcontract, any insurance contract, or any other contract pertaining to this Project.

3.0.3 CITY'S AUTHORITY

- a. The City of Muskegon shall designate and identify its Authorized Representative(s) and Inspectors.
- b. The Authorized Representative will be responsible for the execution of the work under this Contract. The Authorized Representative will determine the amount, quality, acceptability of materials, and fitness of the work to be paid for under this Contract. That Representative will decide all questions which may arise in relation to said work and the construction thereof. The City's estimates and decisions shall be final and conclusive, except as herein otherwise expressly provided.
- c. Inspectors will work under the direct supervision of the Authorized Representative. Inspectors will not be authorized to revoke, alter, enlarge or relax any of these specifications nor to change the plans in any particular. The Inspector on the work will inform the Authorized Representative as to the progress of the work, the manner in which it is being done, and the quality of the materials being used. He/She will also call to the attention of the Contractor any failure to follow the plans and specifications that may be observed. He/She shall have the authority to prevent any material from being used, and to stop any work from being done, which he/she believes does not conform to the plans and specifications, until the Authorized Representative has an opportunity to inspect the material or work. In no instance shall any action or omission on the part of the Inspector relieve the Contractor of the responsibility of completing the work in accordance with the plans and specifications.
- d. In case any question shall arise between the parties hereto relative to said Contract, the determination or decision of the City shall be a condition precedent to the right of the Contractor to receive any money or payment for work under this Contract affected in any manner, or to any extent, by such question.
- e. The City shall decide the meaning and intent of any portion of this Contract or any specifications therein where the same may be found obscure or in dispute. Any differences or conflicts in regard to the work which may arise between the Contractor under this Contract and other contractors performing work for the City shall be adjusted and determined by the City.

3.0.4 OTHER CONTRACTS - The City may award, or may have awarded, other contracts for additional work in the vicinity of this Project; and the Contractor shall cooperate fully with such other contractors by scheduling his/her own work with that to be performed under other contracts as may be directed by the City. The Contractor shall not commit or permit any act which will interfere with the performance of work by any other contractor as scheduled.

3.0.5 TERMINATION OF CONTRACT

- a. If the Contractor refuses or fails to prosecute the work with such diligence as will ensure its completion within the time specified, or as amended, in these Contract Documents, the City may, by written notice, terminate the Contractor's right to proceed with the work.
- b. Upon such termination, the City of Muskegon may take over the work and prosecute same to completion, by contract or otherwise, and may take possession of, and utilize in completing the work, such materials, tools, equipment and plant as may be on the site of the work and necessary to the completion thereof.
- c. The Contractor and the sureties to the Contract shall be liable to the City for any additional cost incurred by the City in its completion of the work, and shall further be liable for the liquidated damages for any delay in completion of work as provided by this Contract.

3.0.6 REVIEW BY AUTHORIZED REPRESENTATIVES - The City of Muskegon, its authorized representative(s) and/or agents shall at all times have access to, and be permitted to observe and review, all work, materials, equipment, payrolls, personnel records, employment conditions, material invoices, and other relevant data and records pertaining to this Contract, however, that all instructions and approval with respect to the work will be given to the Contractor by the City of Muskegon through its Authorized Representative.

3.0.7 GENERAL GUARANTY

- a. Final acceptance of the work will be acknowledged in writing to the Contractor by the City of Muskegon. Neither the final certificate of payment, any provision in the Contract, nor partial or entire use of the improvements embraced in this Contract by the City or the public shall constitute an acceptance of work not done in accordance with the Contract; nor shall such certificate, provision or use relieve the Contractor of liability in respect to any express warranties or responsibilities for faulty materials or workmanship.
- b. The period of guarantee shall not begin until the date of final written acceptance by the City of all work required. The Contractor shall promptly remedy any defects in the work and pay for the damage to other work resulting therefrom which shall appear within a period of twelve (12) months from the date of final acceptance of the work.

3.0.8 WARRANTY OF TITLE

- a. No material, supplies or equipment for the work shall be purchased subject to any chattel mortgage or under conditional sale or other agreement by which an interest therein, or in any part thereof, is retained by the seller or supplier.
- b. The Contractor shall warrant good title to all materials, supplies and equipment installed or incorporated in the work and, upon completion of all work, shall deliver the same, together with all improvements and appurtenances constructed or placed thereon by him/her, to the City of Muskegon free from any claims, liens or charges.
- c. Neither the Contractor nor any person, firm or corporation furnishing any material and/or labor for any work covered by this Contract shall have any right to a lien upon any improvement or appurtenance thereon.
- d. Nothing contained in this paragraph, however, shall impair:
 - i. The right of persons furnishing materials or labor to recover funds owed them under any bond given by the Contractor for their protection;
 - ii. Any rights under any law permitting such persons to look to funds due the Contractor yet in the hands of the City.
- e. The provisions of this Subsection 5 shall be inserted in all Subcontracts and material contracts; and notice of its provisions shall be given to all persons furnishing materials for the Project when no formal contract is entered into for such materials.

3.0.9 PATENTS - The Contractor shall hold and save the City of Muskegon, its officers and employees, harmless from liability of any nature or kind, including costs and expenses, for or on account of any patented or unpatented invention, process article, or appliance manufactured or used in the performance of the Contract, including its use by the City of Muskegon.

3.0.10 PAYROLLS AND BASIC RECORDS

- a. The Contractor will submit weekly a copy of all payrolls, basic records relating thereto, and completed forms as requested, to the City's Affirmative Action Department accompanied by a "Weekly Statement of Compliance". The prime Contractor shall be responsible for the submission of copies of payrolls of all Subcontractors. *
- b. The Contractor shall submit to the City such schedule of quantities and costs, progress schedules, payrolls, reports, estimates, records and other data as the City may request from time to time concerning the work performed under this Contract.
- c. The Contractor shall withhold Muskegon City Income Taxes from each and every employee who is subject to same, and shall pay Contractor's Income Tax due, if any. Contractor shall further require the same of each Subcontractor, consultant or other pay with whom the contractor works or from whom contractor obtains goods or services for the project. Payroll submissions required by this agreement shall include full information showing said withholding. The City may withhold payments otherwise due to the contractor to assure compliance with this agreement or cure noncompliance.

3.0.11 SIGNS AS REQUIRED

- a. The signs that may be required for this project by the Department of HUD, the National Historic Preservation organizations, or other pertinent funding agencies which may require significant posting on the job site, will be provided and erected by the Contractor as incidental to the Contract.
- b. The Contractor shall maintain these signs in good condition throughout the life of this contract.

3.0.12 NATIONAL HISTORIC PRESERVATION ACT OF 1966 - The Contractor agrees to contribute to the preservation and enhancement of structures and objects of historical, architectural or archaeological significance when such items are found and/or unearthed during the course of the project, and to consult with the State Historic Preservation Officer for recovery of the items: [Reference: National Historic Preservation Act of 1966 (80 Stat 915, 16 USC 470) and Executive Order No. 11593 of May 31, 1971] AND to assure Subcontractor's compliance as well.

3.0.13 CLEAN AIR ACT - The Contractor shall comply and shall require each of its Subcontractors employed in the completion of this project to comply with all applicable provisions of the Clean Air Act as amended by Public Law 91-604.*

3.0.14 SOIL EROSION AND SEDIMENT CONTROL ACTS

- a. Public Acts 346 and 347 as amended shall be observed and enforced while working under these documents. Necessary permits for both Acts shall be obtained by the City of Muskegon. Enforcement for Act 346 shall be by the Michigan Department of Natural Resources, and the enforcing agent for Act 347 shall be the City of Muskegon.
- b. The Contractor shall conduct his/her work in such a manner that soil, fuels, oil, bituminous materials, chemicals, sanitary sewage and other harmful materials resulting from the execution of this project are confined within project limits and prevented from entering watercourses, rivers, lakes or reservoirs. All applicable regulations of fish and wildlife agencies and statutes relating to the prevention and abatement of pollution shall be complied with during the performance of this contract. Operations shall be conducted in such a manner as to reduce erosion to the practicable minimum to prevent damaging sedimentation of watercourses, streams or lakes.*
- c. The Contractor shall be responsible for utilizing various measures of control in his/her own work and that of Subcontractors to prevent erosion and sediment damage. When applicable, these measures and requirements will be identified and provided on the plans or in the Special Specifications. They are, however, not to be considered all-inclusive, as additional protective measures may be required as the work progresses. No payment will be allowed for this work.

3.0.15 SOIL REMOVAL AND DUMPING ORDINANCE - Under City ordinance, a permit must be obtained from, and a \$150 fee paid to, the City of Muskegon Building Inspection Department IF excavated or excess soil materials become the property of the Contractor AND those materials are to be deposited as fill within the corporate limits of the City of Muskegon; OTHERWISE, no permit will be required of the Contractor while working on the Project covered by this Contract.

3.0.16 PERMITS AND CODES

- a. The Contractor shall give all notices required by and comply with all applicable laws, ordinances and codes of the local government. All construction work and/or utility installations shall comply with all applicable ordinances and codes including all written waivers. Before installing any work, the Contractor shall examine the drawings and the Specifications for compliance with applicable ordinances and codes, and shall immediately report any discrepancy to the City.
- b. Where the requirements of the drawings and Specifications fail to comply with such applicable ordinances and codes, the City will adjust the Contract by Change Order to conform to such ordinances and codes (unless waivers in writing covering the difference have been granted by the governing body or department) and make appropriate adjustment in the Contract Price or stipulated Unit Prices.
- c. Should the Contractor fail to observe the foregoing provisions and proceed with the construction and/or install any utility at variance with any applicable ordinance or code, including any written waivers (notwithstanding the fact that such installation is in compliance with drawings, Technical or Special Specifications), the Contractor shall remove such work without cost to the City, but a Change Order may be issued to cover only the excess cost the Contractor would have been entitled to receive if the change had been made before he/she commenced work on the items involved.
- d. The Contractor shall at his/her own expense secure and pay for all necessary permits to execute the work from each involved governmental unit, whether it be the City of Muskegon, townships, County or State of Michigan. In some cases, certain permits will be obtained by the owner and will be so identified within the Special Specifications. All other permits are the responsibility of the Contractor.
- e. The Contractor shall comply with applicable local and state laws and ordinances governing the disposal of surplus excavation materials, debris and rubbish on or off the Project Site and commit to trespass on any public or private property in any operation due to or connected with the improvements embraced in this Contract.

3.0.17 TRAFFIC CONTROL - The Contractor shall at all time so conduct his/her work as to ensure the least possible obstruction to traffic. The safety and convenience of the general public and the residents in or adjacent to the Project Site and the protection of persons and property shall be provided for by the Contractor. The Contractor shall provide and maintain adequate barricades, signs, lights and flags to warn and guide the public, and shall provide flagmen and watchmen when needed or when so ordered by the City in full accordance with the MICHIGAN MANUAL OF UNIFORM TRAFFIC ONTROL DEVICES, published and revised from time to time by the Michigan Department of Transportation. The Contractor shall be responsible for compliance with this Item by all Subcontractors as well.*

3.0.18 REQUIRED PROVISIONS DEEMED INSERTED - Each and every provision of law and clause required by law to be inserted in this Contract shall be deemed to be inserted herein, and the Contract shall be read and enforced as though it were included herein; and, if through error or otherwise, any such provision is not inserted, or is incorrectly inserted, then upon the application of either party to this Contract, the Contract shall forthwith be physically amended to make such insertion or correction. This clause shall be included in all Subcontracts.*

3.0.19 COMMUNICATIONS

- a. All notices, demands, requests, instructions, approvals, proposals and claims must be in writing.
- b. Any notice to or demand upon the Contractor from the City relative to any part of this Contract shall be sufficiently considered given, and the service thereof completed, when said notice is posted, by certified or registered mail, to the Contractor at his/her last given address; or when said notice is delivered in person to the Contractor or authorized representative on the Project Site, at the office

of the Contractor, or to any telegraph company for transmission with charges prepaid, in each case addressed to such office.

- c. All papers required to be delivered to the City of Muskegon shall be delivered to the Muskegon City Hall, to the attention of the Authorized Representative on this Project, and any notice to or demand upon the City shall be sufficiently given if so delivered, or if posted, by certified or registered mail, to 933 Terrace Street, Muskegon, Michigan 49443, or to any telegraph company for transmission with charges prepaid, in each case to the same address. Any such notice shall be deemed to have been given as of the time of the actual delivery or at the time of actual receipt, as the case may be.

3.0.20 REQUEST FOR SUPPLEMENTARY INFORMATION - It shall be the responsibility of the Contractor to make timely requests of the City for any additional information not already in his/her possession which should be furnished by the City under the terms of this Contract, and which he/she will require in the planning and execution of the work. Such requests may be submitted from time to time as the need arises, but each shall be filed in ample time to permit appropriate action to be taken by all parties involved so as to avoid delay. Each request shall be in writing, listing the various items and the latest date by which each will be required by the Contractor. The first list shall be submitted within two (2) weeks after the Contract award, and shall be as complete as possible at that time. The Contractor shall, upon request, furnish promptly any assistance and information the City may require in responding to these requests. The Contractor shall be fully responsible for any delay in his/her work or to others arising from his/her failure to comply fully with the provision of this Article.

3.0.21 PROGRESS SCHEDULE AND NOTIFICATION REQUIREMENTS

- a. Immediately after execution of the Agreement, the Contractor shall submit for approval a carefully prepared Progress Schedule showing the proposed dates of starting and completing each of the various sections of work. The work which the Contractor is required to perform under this Contract shall commence at the time stipulated by the City in its Notice to Proceed and shall be fully completed by the dates indicated in the Contract Agreement.
- b. The Contractor shall notify the City's Authorized Representative as to the exact time at which he/she proposes to begin any part of the work at least 48 hours in advance of any such start so that line and grade can be established and inspections provided.
- c. When work is to be done by City forces, in coordination with City forces, or if City of Muskegon utilities need to be located and/or marked, the Contractor shall provide at least 48 hours' advance notice to the City Department from which the work is requested.
- d. The Contractor shall notify "Miss Dig" 48 hours in advance of any work start to allow sufficient time for utility identification and location. The City of Muskegon is NOT a part of the "Miss Dig" program.
- e. Before permission can be granted by the Authorized Representative for street closures, it shall be the Contractor's responsibility to notify the police and fire departments and the Department of Public Works and Utilities.

3.0.22 PAYMENTS BY THE CONTRACTOR

- a. The Contractor shall provide and pay for all materials, labor, tools, equipment, water, lights, heat, power, transportation, superintendence, temporary construction of every nature, charges, levies, fees or other expenses, and all other services and facilities of every nature necessary for the performance of this Contract and delivery of all improvements embraced therein within the specified time.
- b. The Contractor shall pay for all transportation and utility services not later than the 20th day of the calendar month following that in which services are rendered.
- c. The Contractor shall pay for all materials, tools, and other expendable equipment to the extent of 90% of the cost thereof, not later than the 20th day of the calendar month following that in which such materials, tools and equipment are delivered at the Project Site, and the balance of cost thereof not later than the 30th day following the completion of that part of the work in or on which such materials, tools and equipment are incorporated or used.
- d. The Contractor shall pay to each of his/her Subcontractors, not later than the 5th day following each payment to the Contractor, the respective amounts allowed him/her on account of the work performed by the Subcontractors to the extent of each Subcontractor's interest therein.

3.0.23 SUBCONTRACTS

- a. The Contractor shall not execute an agreement with any Subcontractor or permit any subcontractor to perform any work included in this Contract until he/she has submitted a non-collusive affidavit from the subcontractor and received written approval of such subcontractor from the City of Muskegon.
- b. The Contractor shall be as fully responsible to the City of Muskegon for the acts and omissions of his/her Subcontractors, and of persons either directly or indirectly employed by them, as he/she is for the acts and omissions of persons directly employed by the Contractor.
- c. The Contractor shall cause appropriate provisions to be inserted in all Sub-contracts relative to compliance by each Sub- contractor with the provisions of this Contract.
- d. No proposed Subcontractor shall be disapproved by the City of Muskegon except for cause. Nothing contained in this Contract shall create any contractual relation between any Subcontractor and the City of Muskegon.

3.0.24 INSURANCE AND INDEMNITY

- a. Hold Harmless Agreements. To the fullest extent permitted by law, Contractor and Subcontractors agree to defend, pay in behalf of, indemnify, and hold harmless the CITY OF MUSKEGON, all elected and appointed officials, all employees and volunteers, all boards, commissions, and/or authorities and board members, including employees and volunteers thereof working on behalf of the CITY OF MUSKEGON against any and all claims, demands, suits, or loss, including all costs connected therewith, and for any damages which may be asserted, claimed or recovered against or from the CITY OF MUSKEGON and their elected and appointed officials, employees, volunteers, or others working on behalf of the CITY OF MUSKEGON by reason of personal injury, including bodily injury and death, property damage, including loss of use thereof, and/or the effects of or release of toxic and/or hazardous material which arises out of or is any way connected or associated with this contract. The obligation to defend and hold harmless extends to Contractor's employees, agents, subcontractors, assigns and successors.
- b. The contractor, or any of their subcontractors, shall not commence work under this contract until they have obtained the insurance required under this paragraph, and shall keep such insurance in force during the entire life of this contract. All coverage shall be with insurance companies licensed and admitted to do business in the State of Michigan and acceptable to the CITY OF MUSKEGON. The requirements below should not be interpreted to limit the liability of the Contractor. All deductibles and SIR's are the responsibility of the Contractor.
- c. **The Contractor shall procure and maintain the following insurance coverage:**
 - i. Workers' Compensation Insurance- The Contractor and Subcontractor shall procure and maintain during the life of this contract, Workers' Compensation Insurance, including Employers Liability Coverage in accordance with all applicable Statutes of the State of Michigan.
 - ii. Commercial General Liability Insurance - The Contractor shall procure and maintain during the life of this contract, Commercial General Liability Insurance on an "Occurrence Basis" with limits of liability not less than \$1,000,000.00 per occurrence and aggregate combined. Coverage shall include the following extensions: (A) Contractual Liability; (B) Products and Completed Operations; (C) Independent Contractors Coverage; (D) Broad Form General Liability Extensions or equivalent, if not already included. Personal Injury, Bodily Injury and Property Damage coverage's shall be included (E) Deletion of all explosion, collapse and underground (SCU) exclusions, if applicable. The said insurance shall cover liability caused by the activities of any subcontractor.
 - iii. Automotive Liability - The Contractor shall procure and maintain during the life of this contract Automotive Liability Insurance, including Michigan No-Fault Coverage's, with limits of liability for third party claims of not less than \$1,000,000.00 per occurrence or combined single limit Bodily Injury and Property Damage. Coverage shall include all owned vehicles, all non-owned vehicles and all hired vehicles. The said insurance shall cover liability caused by the activities of any subcontractor.

- iv. Additional Insured- Commercial General Liability and Automotive Liability Insurance, as described above, shall include an endorsement stating the following shall be "Additional Insureds" using the following language: "The CITY OF MUSKEGON and all elected and appointed officials, all employees and volunteers, all boards, commissions and/or authorities and board members, including employees and volunteers thereof. It is understood and agreed by naming The CITY OF MUSKEGON as additional insured, coverage afforded is considered to be primary and any other insurance The City of Muskegon may have in effect shall be considered secondary and/or excess.
- v. Cancellation Notice- All policies as described above, shall include an endorsement stating that it is understood and agreed Thirty (30) days, Ten (10) days for non-payment of premium, Advance Written Notice of Cancellation, Non-Renewal, Reduction, and/or Material Change shall be sent to: CITY OF MUSKEGON ENGINEERING DEPARTMENT", PO Box 0536, Muskegon, MI 49443-0536
- d. Owner's and Contractor's Protective Liability- The Contractor shall procure and maintain during the life of this contract Owner's and Contractor's Protective Liability with limits of liability not less than \$1,000,000.00 per occurrence and/or aggregate, combined single limit. Personal injury, Bodily injury and Property Damage coverage's shall be included. The CITY OF MUSKEGON shall be "Named Insured" on this coverage. Thirty (30) day notice of cancellation to the CITY OF MUSKEGON shall be required. Said insurance shall cover liability caused by the activities of any subcontractor(s) either by means of a rider attached to the Prime Contractor's Certificate of Insurance indicating this coverage for subcontractors; or the subcontractor(s) shall submit their own Certificate of Insurance.
- e. Proof of Insurance Coverage - The Contractor and Subcontractors shall provide the CITY OF MUSKEGON at the time the contracts are returned by him/her for execution, a Certificate of Insurance as well as the required endorsements. In lieu of required endorsements, if applicable, a copy of the policy sections where coverage is provided for additional insured and cancellation notice would be acceptable. Copies or certified copies of all policies mentioned above shall be furnished. Certificates and policies endorsing the City of Muskegon as additional insured as listed below:
 - i. Two (2) copies of Certificate of Insurance for
 - ii. Workers' Compensation Insurance;
 - iii. Two (2) copies of Certificate of Insurance for Commercial General Liability Insurance;
 - iv. Two (2) copies of Certificate of Insurance for Automotive Liability Insurance;
 - v. Original Policy, or original Binder pending issuance of policy, for Owner's and Contractor's Protective Liability Insurance;
 - vi. If so requested, Certified Copies of all policies mentioned above will be furnished.
- f. If any of the above coverage's expires during the term of this contract, the Contractor and Subcontractors shall deliver renewal certificates and/or policies to CITY OF MUSKEGON at least ten (10) days prior to the expiration date.

3.0.25 MATERIALS AND WORKMANSHIP

- a. Unless otherwise specifically provided for in the Technical or Special Specifications, all workmanship, equipment, materials and articles the work shall be new and the best grade of the respective kinds for the purpose. Where equipment, materials, articles or workmanship are referred to as "equal to" any particular standard, the City of Muskegon will decide the question of equality.
- b. The City of Muskegon may require the Contractor to dismiss from this Project such employee(s) as the City of Muskegon may deem incompetent, careless, and/or insubordinate.

3.0.26 SUPERINTENDENCE BY CONTRACTOR

- a. Except where the Contractor is an individual and gives his/her personal superintendence to the work, the Contractor shall provide a competent superintendent, satisfactory to the City of Muskegon, on the work at all times during working hours with full authority to act for the Contractor. The Contractor shall also provide adequate staff for the proper coordination and expediting of the work.
- b. The Contractor shall lay out his/her own work, and shall be responsible for all work executed by him/her under this Contract. He/She shall verify all figures and elevations before proceeding with the work and will be held responsible for any error resulting from his/her failure to do so.

3.0.27 FITTING AND COORDINATION OF THE WORK - The Contractor shall be responsible for the proper fitting of all work, and for the coordination of the operations of all trades, subcontractors, or materialmen engaged upon this Contract. He/She shall be prepared to guarantee to each of his/her Subcontractors the locations and measurements which they may require for the fitting of their work to all surrounding work.

3.0.28 MUTUAL RESPONSIBILITY OF CONTRACTORS

- a. If, through acts or neglect on the part of the Contractor, any other contractor or any subcontractor shall suffer loss or damage on the work, the Contractor shall settle with such other contractor or subcontractor by agreement or arbitration, if such other contractor or subcontractor will so settle.
- b. If such other contractor or subcontractor shall assert any claim against the City of Muskegon on account of any damage alleged to have been so sustained, the City will notify the Contractor, who shall defend at his/her own expense any suit based upon such claim, and, if any judgment or claim against the City is allowed, the Contractor shall pay all costs and expenses in connection therewith.

3.0.29 CARE OF THE WORK

- a. The Contractor shall be responsible for all damages to person or property that occur as a result of his/her fault or negligence in connection with the prosecution of the work and shall be responsible for the proper care and protection of all materials delivered and work performed until completion and final acceptance, whether or not the same has been covered in whole or part by payments made by the City.
- b. The Contractor shall provide sufficient competent watchmen, both day and night, including Saturdays, Sundays and holidays, from the time the work commences until final completion and acceptance, as needed.
- c. In an emergency affecting the safety of life, limb or property, including adjoining property, the Contractor, without special instructions or authorization from the City, is authorized to act at his/her own discretion to prevent such threatened loss or injury, and he/she shall so act. He/She shall likewise act if instructed to do so by the City. Any compensation claimed by the Contractor on account of such emergency work will be determined by the City as provided in this Contract regarding Change Orders.
- d. The Contractor shall avoid damage as a result of his/her operation to existing sidewalks, streets, curbs, pavements, utilities (except those which are to be replaced or removed), adjoining property, etc., and he/she shall at his/her own expense completely repair any damage thereto caused by his/her operation.
- e. The Contractor shall shore up, brace, underpin, secure and protect, as may be necessary, all foundations and other parts of existing structures adjacent to, adjoining, and in the vicinity of, the Site which may be in any way affected by the excavations or other operations connected with the execution of this Contract. The Contractor shall be responsible for the giving of any and all required notices to any adjoining or adjacent property owner or other party before commencement of any work. The Contractor shall indemnify and save harmless the City of Muskegon from the damages on account of settlements or the loss of lateral support of adjoining property and from all loss or expense and all damages for which the City may become liable in consequence of such injury or damage to adjoining and adjacent structures and their premises.

3.0.30 SURVEY MONUMENTS

- a. Survey monuments relative to governmental surveys such as a U.S. Coast and Geodetic and the City of Muskegon datum plane reference are to be preserved and left undisturbed by the Contractor. Land survey monuments such as Section corners, 1/4 and 1/8 corners, or other alignment points of reference, including property corners of individual parcels of land, are to be respected and left undisturbed. When found in conflict with proposed work, the Contractor shall immediately notify the Authorized Representative in charge of work, whereupon instructions shall be given to the Contractor for preservation of the Survey Point. If housings or boxes for protection are required, the City shall furnish to the Contractor at no cost the necessary materials. The Contractor, in turn, will install the materials at no cost to the City.
- b. If the Contractor damages or destroys known Survey Points of reference, the Contractor shall be responsible for replacement of the monument. The work must be accomplished by a registered land

surveyor in accordance with accepted procedures for such work. The Contractor shall be responsible for all incurred costs.

3.0.31 SANITARY FACILITIES - The Contractor shall furnish, install and maintain ample sanitary facilities for the workers. As the needs arise, a sufficient number of enclosed temporary toilets shall be conveniently placed as required by the sanitary codes for the state and local government. Drinking water shall be provided from an approved source, so piped or transported as to keep it safe and fresh and served from single-service containers or satisfactory types of sanitary drinking stands or fountains. All such facilities and services shall be furnished in accordance with existing and governing health regulations.

3.0.32 USE OF CITY WATER - Upon request and approval, the Contractor may obtain a water supply from the City of Muskegon fire hydrants at no cost, provided that the following conditions are met and exercised:

- a. The Contractor's superintendent shall obtain from the Water Department Superintendent a proper connection, including a meter to monitor usage.
- b. The Contractor shall only use hydrant wrenches to open and close hydrants; pipe wrenches will not be allowed.
- c. The hydrant shall be fully opened when used; volume shall be controlled by an independent hand valve.
- d. The Contractor's release shall not be granted until the hydrant connection has been returned to the Water Department and such receipt acknowledged.

3.0.33 USE OF PREMISES

- a. The Contractor shall comply with all instructions of the City of Muskegon and the ordinances and codes of the local government regarding signs, advertising, traffic, fires, explosives, danger signals and barricades.
- b. The Contractor shall confine his/her equipment, storage of materials, and construction/demolition operations to the Contract limits as shown on the drawings and as prescribed by ordinances or permits, or as may be directed by the City, and shall not unreasonably encumber the Site or public rights-of-way with his/her materials and equipment.
- c. The Contractor and his/her Subcontractors may maintain such office and storage facilities on the Site as are necessary for the proper conduct of the work. These shall be located so as to cause no interference to any work to be performed on the Site. The City shall be consulted with regard to locations.
- d. The Contractor may furnish and maintain, during the execution of this Project, adequate facilities on the Site or adjacent thereto for the use of the City's representatives.
- e. Upon completion of the Project, or as directed by the City, the Contractor shall remove all such temporary structures and facilities as have been placed on the Site, these to become his/her property, and leave the Project Site in the condition required by the Contract.

3.0.34 PARTIAL USE OF SITE IMPROVEMENTS BY THE CITY - The City of Muskegon, at its election, may give notice to the Contractor and place in use those sections of improvements which have been completed, inspected and can be accepted as complying with the Contract, if each such section is reasonably safe, fit and convenient, in the City's opinion, for the use and accommodation for which it was intended, PROVIDED THAT:

- a. The use of such sections in no way shall impede the completion of the remainder of the work by the Contractor;
- b. The Contractor shall not be responsible for any damages or maintenance costs due directly to the use of such sections;
- c. The use of such sections shall in no way relieve the Contractor of his/her liability due to having used defective materials or due to poor workmanship.

3.0.35 REMOVAL OF DEBRIS, CLEANING, ETC. - The Contractor shall periodically, or as directed during the progress of the work, remove and legally dispose of all surplus excavated material and debris, and keep the Project Site and public rights of way reasonably clear. Upon completion of the work, he/she shall remove all temporary construction facilities, debris and unused materials provided for the work, and put the whole Site of the work and

public rights of way in a neat and clean condition. Trash burning on the Site will be subject to prior approval of the City of Muskegon and existing state and local regulations.

3.0.36 ACCIDENT PREVENTION

- a. The Contractor shall exercise proper precaution at all times for the protection of persons and property and shall be responsible for all damages to persons or property, either on or off the Site, which occur as a result of his/her prosecution of the work. The safety provisions of applicable laws and building, construction or demolition codes shall be observed, and the Contractor shall take, or cause to be taken, such additional safety and health measures as the City may determine to be reasonably necessary.
- b. Machinery, equipment and all hazards shall be guarded in accordance with the safety provisions of the "Manual of Accident Prevention of Construction", published by the Associated General Contractors of America, Inc., to the extent that such provisions are not in conflict with applicable local laws.
- c. The Contractor shall maintain an accurate record of all cases of death, occupational disease and injury requiring medical attention or causing loss of time from work, arising out of and in the course of employment on work under this Contract. The Contractor shall promptly furnish the City with reports concerning these matters.
- d. The Contractor shall indemnify and save harmless the City of Muskegon from any claims for damages resulting from personal injury and/or death suffered or alleged to have been suffered by any person as a result of any work conducted under this Contract.

3.0.37 SPECIFICATIONS AND DRAWINGS

- a. The City of Muskegon will furnish the Contractor without charge one (1) copy of the Contract Documents, including General, Technical and Special Specifications complete with plans, drawings, maps, etc. Additional copies requested by the Contractor will be furnished at cost.
- b. In case of discrepancy, figured dimensions shall govern over scaled dimensions; Bid Proposal over plans; plans over Special Specifications; and Special Specifications over General and Technical Specifications.
- c. When discrepancies are found in drawings or Specifications, the matter shall be immediately submitted to the City, without whose decision said discrepancy shall not be adjusted by the Contractor except at his/her own risk and expense.

3.0.38 SHOP DRAWINGS FROM THE CONTRACTOR

- a. All required shop drawings, machinery details, layout drawings, etc., shall be submitted to the City in three (3) copies for approval sufficiently in advance of requirements to afford ample time for checking, including time for correcting, resubmitting and rechecking, if necessary.
- b. The Contractor may proceed, only at his/her own risk, with manufacture or installation of any equipment or work covered by said Shop Drawings, etc., until they are approved. No claim by the Contractor for extension of the Contract Time will be granted by reason of the Contractor's failure in this respect.
- c. Any drawings submitted without the Contractor's stamp of approval will not be considered and will be returned to him/her for proper resubmission. If any drawings show variations from the requirements of the Contract because of standard shop practice or other reason, the Contractor shall make specific mention of such variation in his/her letter of transmittal in order that, if acceptable, suitable action may be taken for proper adjustment of Contract Price and/or Time; otherwise, the Contractor will not be relieved of the responsibility for executing the work in accordance with the Contract even though the drawings have been approved.
- d. If a shop drawing is in accord with the Contract or indicates only a minor adjustment, in the interest of the City, without involving a change in Contract Price and/or Time, the City may approve the drawing. Such approval shall be general, shall not relieve the Contractor from his/her responsibility for adherence to the Contract or for any error in the drawing, and shall contain substantially the following language:
- e. "The modification shown on the attached drawing is approved in the interest of the City of Muskegon to effect an improvement for the Project and is ordered with the understanding that it

does not involve any change in the Contract Price or Time; that it is subject generally to all Contract stipulations and covenants; and that it is without prejudice to any and all rights of the City of Muskegon under the Contract and surety bond or bonds.”

3.0.39 SAMPLES, CERTIFICATES AND TESTS

- a. The Contractor shall submit all equipment samples, certificates, affidavits, etc., as called for, or as required by the City, promptly after award of the Contract and acceptance of the Contractor’s bond.
- b. The Contractor shall furnish promptly all materials reasonably necessary for any tests which may be required.
- c. No such material or equipment shall be manufactured or delivered to the Site, except at the Contractor’s own risk, until the required samples or certificates have been approved in writing by the City.
- d. Machinery, mechanical or other equipment, materials or articles installed or used without such prior City approval shall be at the risk of subsequent rejection.
- e. Each sample submitted by the Contractor shall carry a label giving the name of the Contractor, the Project for which it is intended, and the name of the producer. Each shall be accompanied by a certificate or letter from the Contractor which shall”
 - i. State that the sample complies with the Contract requirements;
 - ii. Give the name and brand of the product and its place of origin;
 - iii. Give the name and address of the producer;
 - iv. Include or be accompanied by all specifications or other detailed information which will assist the City in determining the acceptability of the sample promptly;
 - v. Include the statement that all materials or equipment furnished for use in the Project will comply with the samples and/or certified statements.
- f. Where machinery, mechanical or other special equipment is to be installed under this Contract, the Contractor shall furnish each manufacturer’s detailed specifications to the City for approval together with full information in regard to proposed installations.
- g. Materials specified by reference to the number or symbol of a specific standard, such as an A.S.T.M. Standard, a Federal specification or other similar standard, shall comply with requirements in the latest revision thereof and any amendment or supplement thereto in effect on the date of the Invitation for Bids, except as limited to type, class or grade, or modified in such reference. The Standards referred to shall have full force and effect as though printed herein.
- h. Approval of any materials shall be general only, and shall not constitute a waiver of the City’s right to demand full compliance with Contract requirements. With regard to a general approval, the City may reject materials, equipment and accessories for cause after actual delivery to the City and such check tests have been made as deemed necessary in each instance, even though such materials and articles have been given general approval.
- i. The City’s Authorized Representative may test such materials as deemed advisable on the Project Site.
- j. All tests by the City will be performed in such manner as not to delay the work unnecessarily, and shall be made in accordance with the provisions of the Specifications.
- k. Any delay in the work caused by late or improper submission of samples or certificates for approval shall not be considered just cause for an extension of the Contract Time.
- l. If materials, equipment or accessories which fail to meet check tests have been incorporated in the work, the City will have the right to cause their removal and replacement by proper materials, or to demand and secure such reparation by the Contractor as is equitable.
- m. Except as otherwise specifically stated in this Contract, the costs of sampling and testing will be divided as follows:
 - i. The Contractor shall furnish without extra cost, including packing and delivery charges, all samples required for testing purposes;
 - ii. The Contractor shall assume all costs of re-testing materials which fail to meet Contract requirements;
 - iii. The Contractor shall assume all costs of testing materials offered in substitution for those found deficient; and

- iv. The City of Muskegon will pay all other expenses for testing.
- n. Certificates of Compliance: In lieu of test samples and upon request of the City, the Contractor shall provide, upon delivery and through his/her supplier, a witnessed, notarized and signed certification complete with documented test results that the material meets or exceeds the desired specifications. The signer of the certification must be titled officer of the material company, and the documented test results must be obtained through an independent testing laboratory. Costs for such documentation shall be borne by the Contractor.

3.0.40 INSPECTION BY THE CITY

- a. All materials and workmanship shall be subject to inspection, examination, and/or test by the City of Muskegon at any and all time during manufacture or construction and at any and all places where such manufacture or construction is carried on. The inspection of materials as a whole, or in part, will generally be made at the Project Site, subject to the provisions of paragraph b following.
- b. Inspection of materials and appurtenances to be incorporated in the improvements embraced in this Contract may be made at the place of production, manufacture or shipment whenever the quantity justifies it. Such inspection and acceptance, unless otherwise stated, shall be final, except in regard to (1) latent defects, (2) departures from specific requirements of the Contract, (3) damage or loss in transit, or (4) fraud or such gross mistakes as amount to fraud.
- c. The City shall have the right to reject defective material and workmanship or require its correction. Unacceptable workmanship shall be satisfactorily corrected. Rejected material shall be promptly segregated and removed from the Project Site and replaced with material of specified quality without charge therefor.
- d. If the Contractor fails to proceed at once with the correction of rejected workmanship or defective material, the City may, by contract or otherwise, have the defects remedied, or rejected materials removed from the project area, and charge the cost of the same against the monies which may be due the Contractor without prejudice to any other rights or remedies of the City.
- e. The Contractor shall notify the City sufficiently in advance of back-filling or concealing any facilities to permit proper inspection. If any facilities are concealed without approval or consent of the City, the Contractor shall uncover for inspection, and recover, such facilities all at his/her own expense, when so requested by the City of Muskegon.
- f. Should it be considered necessary or deemed advisable by the City at any time before final acceptance of the entire work to make an examination of work already completed by uncovering the same, the Contractor shall, on request, promptly furnish all necessary facilities, labor and/or material.
- g. If such work is found to be defective in any important or essential respect due to the fault of the Contractor or the fault of his/her Subcontractors, the Contractor shall defray all the expenses of such examination and or satisfactory reconstruction.
 - i. If, however, such work is found to meet the requirements of the Contract, the actual cost of labor and material necessarily involved in the examination and replacement, plus 15% of such costs to cover superintendence, general expenses and profit, shall be allowed the Contractor; and he/she shall be granted in addition a suitable extension of time if completion of the work under the entire Contract has been delayed on account of the additional work involved by such request.
 - ii. A semi-final inspection will be scheduled by the City when all construction has been completed.
 - iii. When the City has accomplished its semi-final inspection, determined all deficiencies (if any) have been corrected, and the project is completed and functional, a final inspection will be scheduled.
- h. Neither inspection, testing, approval nor acceptance of the work in whole or in part by the City or its agents shall relieve the Contractor or his/her sureties of full responsibility for materials furnished or work performed not in strict accordance with the Contract.

3.0.41 CHANGES IN THE WORK

- a. Except for the purpose of affording protection against any emergency endangering life or property, the Contractor shall make no change in the materials used; in the specified manner of constructing

- and/or installing the Improvements; nor supply additional labor, services or materials beyond that actually required for the execution of the Contract, unless pursuant to a written order from the City authorizing the Contractor to proceed with the change. No claim for an adjustment of the contract price will be valid unless so ordered.
- b. The City may make changes in the scope of the work required to be performed by the Contractor under the Contract; make additions thereto; or omit work therefrom without invalidating the Contract; without relieving or releasing the Contractor from any of his/her obligations under the Contract or any guarantee given by him/her pursuant to the Contract; without affecting the validity of the guaranty bonds; and without relieving or releasing the surety or sureties of said bonds.
 - c. All such changes in work shall be executed under the terms of the original Contract as expressly provided for.
 - d. In the case where unit prices ARE contained in the Agreement, the City may order the Contractor to proceed with desired changes in the work with the value of such changes being determined by the measured quantities involved and the applicable unit prices specified in the Contract, unless said changes increase or decrease the total contract price more than twenty-five percent (25%).

3.0.42 CHANGE ORDERS

- a. Change Orders shall be executed:
 - i. If applicable unit prices ARE NOT contained in the Proposal;
 - ii. If the total net change ordered by the City increases or decreases the contract price more than twenty-five percent (25%);
 - iii. If it becomes necessary to revise the completion date due to causes which are not the fault of the Contractor;
 - iv. Upon successful completion of the Project and after final quantities are in confirmation, a Change Order Balance shall be made out by the Authorized Representative and executed by both parties. This quantity balance shall identify the total project cost and allow the Contractor to present the written Request for Final Payment.
- b. **Acceptable Methods for Cost Determination:**
 - i. Unit Price Method – The City shall request and the Contractor shall submit a written proposal describing each individual unit of work and the unit price for each item.
 - ii. Lump Sum Method – The City shall request and the Contractor shall submit a written proposal describing the work and the lump-sum price for the described work.
 - iii. Cost-Plus, Limited Basis Method – If other methods are not acceptable and prompt agreement between the parties cannot be reached, the City may order the Contractor to proceed with the work on a cost-plus, limited basis. A Cost-Plus, Limited Basis is defined as the net cost of the Contractor’s labor, materials and equipment plus 15% of said net cost to cover overhead and profit. The total cost not to exceed an amount to be specified.
 1. Costs not eligible to be included in the Cost-Plus, Limited Basis are: Insurances, bonds, payroll costs for the Contractor’s officers or executives, managers, engineers, lawyers or administrative personnel. These typical costs are to be considered a part of the overhead factor.
 - iv. City of Muskegon Credit Method – If the City deems it not expedient to require the Contractor to correct work not done in accordance with the Contract, the City may issue a Credit Change Order to create an equitable deduction from the Contract Price. Said deduction will be made by agreement between the Contractor and the City of Muskegon and subject to settlement, in case of dispute, as provided in these Documents.
- c. Change Order Procedure – After the Contractor’s proposal has been reviewed and found acceptable by both parties, the City will prepare a Change Order in accordance therewith for execution by the Contractor on the appropriate form required by the funding agency or by using the City of Muskegon change order form.
- d. **Change Order Procedure Documentation shall include:**
 - i. A detailed reason for and description of the work, its location, quantity, rate and method of payment as described above.
 - ii. A definite statement as to the resulting change in the Contract Price and/or time.

- iii. The statement that all work involved in the change shall be performed in accordance with the Contract requirements except as modified by this Change Order.

3.0.43 DISPUTES AND CLAIMS

- a. All disputes arising under this Contract or its interpretation, except those disputes covered by Federal Labor Provisions, whether involving law or fact, or both, or extra work, and all claims for alleged breach of Contract shall be presented by the Contractor to the City for decision within ten (10) days of commencement of dispute.
- b. All papers pertaining to claims shall be filed in quadruplicate. Such notice need not detail the amount of the claim but shall state the facts surrounding the claim in sufficient detail to identify and prove the claim, together with its character and scope. In the meantime, the Contractor shall proceed with the work as directed.
- c. Any claim not presented within the time limit specified in Paragraph (a) above shall be deemed to have been waived, except that if the claim is of a continuing character and notice of the claim is not given within then (10) days of its commencement, the claim will be considered only for a period commencing ten (10) days prior to the receipt by the City of notice thereof.
- d. After review of the claim, the City will decide upon action to be taken. Each decision by the governing body of the City of Muskegon will be in writing and will be mailed to the Contractor by registered mail, return receipt requested, directed to his/her last known address.
- e. If the Contractor does not agree with any decision of the City, he/she shall in no case allow the dispute to delay the work but shall notify the City promptly that he/she is proceeding with the work under protest, and he/she may then except the matter in question from the final release upon Request for Final Payment in substantially.

3.0.44 CLAIMS FOR EXTRA COST

- a. If the Contractor claims that any instructions by drawings or otherwise involve extra cost or extension of time, he/she shall, within ten (10) days after the receipt of such instructions, and in any event before proceeding to execute the work, submit his/her protest thereto in writing to the City stating clearly and in detail the basis of this objection. No such claim will be considered unless so made.
- b. Claims for additional compensation for extra work due to alleged errors in ground elevations, contour lines, or bench marks will not be recognized unless accompanied by certified survey data made prior to the time the original ground was disturbed, which clearly shows that errors exist which resulted, or would result, in handling more material or performing more work than would be reasonably estimated from the drawings and maps issued.
- c. Any discrepancies which may be discovered between actual conditions and those represented by the drawings and maps shall at once be reported to the City, and work shall not proceed except at the Contractor's risk until written instructions have been received by him/her from the City.
- d. If, on the basis of the available evidence, the City determines that an adjustment of the Contract Price and/or Contract Time is justifiable, the procedure shall be as provided in Item 39 (Part 3, Section I), Change Orders.

3.0.45 DELAYS AND LIQUIDATED DAMAGES

- a. Liquidated Damages for Delays. If the work is not completed within the time stipulated in this Contract, including any extensions of time for excusable delays as provided, the Contractor and/or his sureties shall be liable for and shall pay to the City of Muskegon sum of three hundred dollars (\$300.00) for each calendar day of delay as fixed, agreed and liquidated damages (it being impossible to determine the actual damages occasioned by the delay), commencing from the time stipulated for completion until such work is satisfactorily completed and accepted.
- b. Excusable Delays. The right of the Contractor to proceed shall not be terminated nor shall the Contractor be charged with liquidated damages for any delays in the completion of the work DUE TO:
 - i. Any acts of government, including controls or restrictions upon or requisitioning of materials, equipment, tools or labor by reason of war, national defense or any other national emergency;

- ii. Any acts of the City of Muskegon;
- iii. Causes not reasonably foreseeable by the parties to this Contract at the time of the execution of the Contract which are beyond the control and without the fault or negligence of the Contractor including, but not restricted to: Acts of God or of the public enemy; acts of another contractor in the performance of some other contract with the City; fires; floods; epidemics; quarantine; restrictions; strikes; freight embargoes; and weather of unusual severity such as hurricanes, tornadoes, cyclones and other extreme weather conditions; and
- iv. Any delay of any Subcontractor occasioned by any of the causes specified in subparagraphs 1, 2 and 3 above.

PROVIDED, HOWEVER, that the Contractor promptly notify the City within ten (10) days in writing of the cause of the delay.

- c. Upon receipt of such written notification, the City shall ascertain the facts and the cause and extent of the delay. If, upon the basis of the facts and in compliance with the terms of this Contract, the delay is properly excusable, the City shall extend the time for completing the work for a period of time commensurate with the period of excusable delay through the execution of a written Change Order.

3.0.46 PAYMENTS TO THE CONTRACTOR

a. Partial Payments

- i. Partial payments will be made as specified herein for work completed and for fabricated or processed non-perishable materials delivered for the use on the project. Processing of payments will be completed as soon as practicable; however, no claim will be considered for late payment of estimates.
- ii. Partial payments will be issued on the second Friday of each month on the basis of the value of the work completed during the estimate period, less the percentage retained as specified herein, provided the written orders of the Engineer have been or are being fulfilled, provided the time for completion has not elapsed, and provided that at least one-half of the contract amount or \$1,000 has been earned during the estimate period. Said payments will be based upon estimates prepared by the Engineer of the value of the work performed, and estimates of the Engineer are subject to final balancing at the time of the final estimate. In the event that the prepared estimate is not submitted with sufficient time to process payment on the second Friday of the month, payment of the estimate will be processed for payment on the fourth Friday of the month. As a result, the Engineer's estimates may not be relied upon by a Contractor as a basis to make payment to a Subcontractor.
- iii. Before each payment by the City to the Contractor under this contract, the Contractor shall furnish the City with a certificate in duplicate, substantially to the effect that the Contractor and each Subcontractor has complied with the wage and other labor standards provisions of this contract. The Form of certificate to be used will be furnished by the City.
- iv. Before making any partial payment, the City may require the Contractor to present a verified written statement showing the amounts he/she owes for labor performed and materials furnished along with the names and addresses of the persons to whom which sums are due.
- v. In case the Contractor shall have sublet a part of the work, the statement shall also show the sum owed to the Subcontractor showing names and addresses of persons performing labor or furnishing material under that subcontract along with the respective amounts due such persons.
- vi. The City must pay the amounts due directly to the creditors of the Contractor or Subcontractor so listed, deducting the amount from that due the Contractor or Subcontractor.
- vii. Partial payments made by the City to the Contractor are monies advanced for the purpose of assisting the Contractor to expedite the work under this contract. The Contractor shall be responsible for the care and protection of all materials and work upon which payments have been made until final acceptance of such work and materials by the City.
- viii. Any such partial payments shall not constitute a waiver of the right of the City to require the fulfillment of all terms of the contract, and the delivery of all improvements embraced therein, complete and satisfactory in all details.

b. Withholding Payments

- i. The City may withhold from any payment otherwise due the Contractor so much as may be necessary to protect the City of Muskegon.
 - ii. The City may also elect to withhold any amounts the Contractor owes to any subcontractor or materials dealer for work performed or materials furnished by them.
 - iii. Any amount due to the City of Muskegon for liquidated damaged, or other purposes as provided under the terms of this contract, shall be deducted from the final payment due the Contractor.
 - iv. The foregoing provisions shall be construed solely for the benefit of
 - v. the City of Muskegon and will not require the City Commission to determine or adjust any claims or disputes between the Contractor and his/her Subcontractors or materials dealers, or to withhold any monies for their protection unless the City Commission elects to do so.
 - vi. The failure or refusal of the City to withhold any monies from the
 - vii. Contractor shall in nowise impair the obligations of any surety or sureties under any bond or bonds furnished under this contract.
 - viii. Right of Setoff. The City is entitled by this agreement to set off and retain from any payment to the Contractor or any Subcontractor or material supplier, all amounts which are due and owing to the City of Muskegon from said Contractor, Subcontractor, or material supplier for any reason,. The said right or setoff also applies to any unpaid taxes to be collected by the City. This right of setoff shall be subject only to the right of a surety providing bonds or guarantees for the project be due and owing to a Subcontractor or material supplier, and which are required to be paid by the surety. If no claim against any such surety has been made, then this right of setoff shall be invoked.
 - ix. This right to setoff shall not apply in the case of non-management individuals employed by a Contractor or Subcontractor who have claims solely for wages earned in the performance of labor in this project. In the event there remain outstanding such claims for labor, the right of setoff shall be subordinate to such claims even though no claim against a surety has been made.
- c. Final Payment
- i. Final payment to the Contractor shall be made subject to the furnishing of a satisfactory release of all claims against the City arising under and by virtue of this contract, other than such claims as may be specifically accepted by the Contractor from the operation of release as provided under "Disputes and Claims".
 - ii. The Contractor shall prepare his/her Requisition for Final Payment after final inspection and acceptance by the City for all work under the contract.
 - iii. The Contractor shall additionally secure the consent of his/her surety in regard to Final Payments as well as the retainage withheld by the City.
 - iv. Requisition for Final Payment can be based upon the total project dollar amount as described in the required Balancing Change Order. The total amount of the final payment will be that amount agreed upon by the parties hereto MINUS all previous payments.
 - v. Before making final payment, the City may require the Contractor to furnish releases or receipts from all Subcontractors having performed any work and from all persons having supplied materials, equipment installed on the project, and services to the Contractor.
 - vi. If the City deems it advisable to make payment in part or full to the Contractor without requiring the furnishing of such releases or receipts, any payments so made shall in nowise impair the obligations or any surety or sureties furnished under this contract.

3.2 CONTRACT CHANGE ORDER

CONTRACTOR		CONTRACT						DATE	11/10/2017	
								CHANGE ORDER		
								No.	1	
ITEM OF WORK	UNIT	QUANTITY	QUANTITY	QUANTITY	QUANTITY	UNIT	AMOUNT	AMOUNT		
DESCRIPTION, REASON, LOCATION OF CHANGE	OF MEASURE	PROPOSAL	AS BUILT	INCREASE +	DECREASE -	COST	INCREASE	DECREASE		
1							\$0.00	\$0.00		
2							\$0.00	\$0.00		
3							\$0.00	\$0.00		
							TOTALS	\$0.00	\$0.00	
CHANGE REQUEST EFFECIVE DATE:										
							ORIGINAL CONTRACT PRICE:	\$0.00		
							NET +/-	\$0.00		
							REVISED CONTRACT PRICE:	\$0.00		
ENGINEERING DEPARTMENT		CONTRACTOR APPROVAL				CITY OF MUSKEGON APPROVAL				
										AUTHORIZED REPRESENTATIVE AND DATE
PREPARED BY	DATE	PRINTED NAME AND TITLE				PRINTED NAME AND TITLE				

MUSKEGON

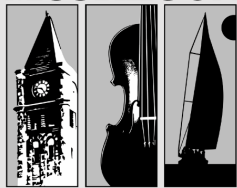

West Michigan's Shoreline City
www.shorelinecity.com

3.3 CONTRACTOR'S CERTIFICATE & RELEASE REQUEST FOR FINAL PAYMENT

FROM: _____
(Name of Contractor)

TO: The City of Muskegon

RE: Contract No.

ENTERED INTO THE _____ DAY OF _____ BETWEEN THE CITY OF MUSKEGON,
933 TERRANCE ST, MUSKEGON, MICHIGAN 49443

AND

(Contractor Street Address) (City) (State) (ZIP)

FOR THE: _____
(Name of Operations to be performed)

UNDER THE CONTRACT ENTITLED: _____

PROJECT NO.

LOCATED IN THE CITY OF MUSKEGON, MICHIGAN;

KNOW ALL MEN BY THESE PRESENTS:

1. The undersigned hereby certifies that there is due from and payable by the CITY OF MUSKEGON to the CONTRACTOR under the Contract and duly approved Change Orders and modifications THE BALANCE OF \$ _____.
2. The undersigned further certifies that in addition to the amount set forth in Paragraph 1, there are outstanding and unsettled the following items which the Contractor claims are just and due and owing by the City of Muskegon to the Contractor:
 - a. _____
 - b. _____
 - c. _____
 - d. _____

(Itemize claims and amounts due; if none, so state)
3. The undersigned further certifies that all work required under this Contract, including work required under Change Orders Nos. _____, has been performed in accordance with the terms thereof, and that there are no unpaid claims for materials, supplies or equipment and no claims of laborers or mechanics for unpaid wages arising out of the performance of this Contract, and that the wage rates paid by the Contractor and all Subcontractors were in conformity with the Contract provisions relating to said wage rates.

4. Except for the amounts stated under Paragraphs 1 and 2 hereof, the undersigned has received from the CITY OF MUSKEGON all sums of money payable to the undersigned under or pursuant to the above-mentioned Contract or any modification or change thereof.
5. That in consideration of the payment of the amount stated in Paragraph 1 hereof, the undersigned does hereby release the CITY OF MUSKEGON from any and all claims arising under or by virtue of this Contract, except the amount listed in Paragraph 2 hereof; provided, however, that if for any reason the City of Muskegon does not pay in full the amount stated in Paragraph 1 hereof, said deduction shall not affect the validity of this release, but the amount so deducted shall be automatically included under Paragraph 2 as an amount which the Contractor has not released but will release upon payment thereof.

The Contractor further certifies that upon the payment of the amount listen in Paragraph 2 hereof, and of any amount which may be deducted from Paragraph 1 hereof, the Contractor will release the City of Muskegon from any and all claims of any nature whatsoever arising out of said Contract or modification thereof, and will execute such further releases or assurances as the City may request.

IN WITNESS WHEREOF, the undersigned has signed and sealed this instrument this _____ day of _____, 20 _____.

(SEAL)

CONTRACTOR: _____

BY: _____

(Printed name and title of signer)

_____, the affiant signing this instrument, being first duly sworn on oath, deposes and says: First, that he/she is the

_____ of the _____
(Title) (Name of company)

Second, that he/she has read the foregoing certificate by him/her subscribed as

_____ of the _____
(Title) (Name of company)

Affiant further states that the matters and things stated are, to the best of his/her knowledge and belief, true.

Affiant: _____

Subscribed and sworn to before me this _____ day of _____, 20 _____

(Notary)

My commission expires _____

3.5 CONSENT OF SURETY

We, as surety on the above described contract, hereby give our consent to the payment to the Contractor as indicated above.

Date*: _____

Signed: _____

(Attorney-in-fact)

NOTE: Two completed copies of this or similar form MUST BE SUBMITTED to and accepted by the City of Muskegon BEFORE REDUCTION OF 10% RETAINAGE AND FINAL PAYMENT WILL BE MADE.

***Date contract awarded by the city commission**

SECTION 2

3.6 AFFIRMATIVE ACTION

NOTICE OF REQUIREMENT FOR AFFIRMATIVE ACTION TO INSURE EQUAL EMPLOYMENT OPPORTUNITY AND PROHIBITING DISCRIMINATION IN EMPLOYMENT

(Federal Executive Order 11243)

Michigan: Elliot-Larson Civil Rights Act

The attention of bidders is particularly called to the requirements for ensuring that employees and applicants for employment are not discriminated against.

During the performance of this contract, the contractor agrees as follows:

The contractor will not discriminate against any employee or applicant for employment because of religion, race, color, national origin, age, sex, height, weight, familial status, marital status, disability, sexual orientation or gender identity, or status as a Vietnam Era Veteran. The contractor will take affirmative action to ensure that applicants are employed and that employees are treated fairly during employment, without regard to their religion, race, color, national origin, age, sex, height, weight, familial status, marital status, disability, sexual orientation or gender identity, or veteran background. Such action shall include, but not be limited to, the following: employment, promotion, demotion, or transfer; recruitment or recruitment advertising, layoff or termination; rates of pay or other forms of compensation; selection for training, including apprenticeship.

LOCAL EMPLOYMENT EFFORT

The City of Muskegon requires that the contractor must hire local trades and labor employees from the City of Muskegon, County of Muskegon and/or this SMSA (Standard Metropolitan Statistical Area) for the duration of this project, insofar as these are available to perform the necessary work. Supervisory and/or technical staff officials are exempt from this requirement.

LABOR STANDARDS PROVISION EMPLOYMENT AND PREVAILING WAGE AND SALARY REQUIREMENTS

The attention of bidders is particularly called to the requirements covered in these documents concerning the payment of not less than the prevailing wage and salary rates specified, and in regard to conditions of employment with respect to certain categories and classifications of employees.

All laborers and mechanics employed by this contract shall be paid unconditionally and not less than once each week, and without subsequent deduction or the rebate on any account (except such payroll deductions as are permitted by the applicable regulations issued by the City of Muskegon).

SECTION 3

3.7 ADOPTED LABOR STANDARDS PROVISIONS

The following clause is applicable unless this contract is exempt under the rules and regulations of the Secretary of Labor issued pursuant to Executive Order No. 11246 of September 24, 1965 (30FR 12319), as amended. During the performance of this contract, the contractor agrees as follows:

- (1) The contractor will not discriminate against any employee or applicant for employment because of race, color, religion, sex or natural origin. The contractor will take affirmative action to ensure that applicants are employed, and that employees are treated during employment, without regard to their race, color, religion, sex, or national origin. Such action shall include, but not be limited to the following: employment, upgrading, demotion, or transfer; recruitment or recruitment advertising; layoff or termination; rates of pay or other forms of compensation; and selection for training, including apprenticeship. The contractor agrees to post in conspicuous place, available to employees and applicants for employment, notices to be provided by the contracting officer setting for the provisions of this nondiscrimination clause.
- (2) The contractor will, in all solicitations or advertisements for employees placed by or on behalf of the contractor, state that qualified applicants will receive consideration for employment without regard to race, color, religion, sex, or national origin.
- (3) The contractor will send to each labor union or representative of workers with which he has a collective bargaining agreement or other contract or understanding, a notice to be provided by the agency contracting officer, advising the labor union or workers' representative of the contractor's commitments under Section 202 of Executive Order No. 1246 of September 24, 1965, and shall post copies of the notice in conspicuous places available to employees and applicants for employment.
- (4) The contractor will comply with all provisions of Executive Order No. 11246 of September 24, 1965, and of the rules, regulations, and relevant orders of the Secretary of Labor.
- (5) The contractor will furnish all information and reports required by Executive Order No. 11246 of September 24, 1965, and by the rules, regulations and orders of the Secretary of Labor, or pursuant thereto, and will permit access to his books, records, and accounts by the contracting agency and the Secretary of Labor for the purposes of investigation to ascertain compliance with such rules, regulations, and orders.
- (6) In the event of the contractor's noncompliance with the nondiscrimination clauses of this contract or with any of such rules, regulations or orders, this contract may be canceled, terminated, or suspended in whole or in part and the contractor may be declared ineligible for further Government contracts in accordance with the procedures authorized in Executive Order No. 11246 of September 24, 1965, and such other sanctions may be imposed and remedies invoked as provided in Executive Order No. 11246 of September 24, 1965, or by rule, regulation, or order of the Secretary of Labor, or as otherwise provided by law.
- (7) The contractor will include the provision of paragraphs (1) through (7) in every subcontract or purchase order unless exempted by rules, regulations, or orders of the Secretary of Labor issued pursuant to Section 204 of Executive Order No. 11246 of September 24, 1965, so that such provisions will be binding upon each subcontractor or vendor. The contractor will take such action with respect to and subcontract or purchase order as may be directed by the Secretary of Labor as a means of enforcing such provisions including sanctions for noncompliance: Provide, however, that in the event the contractor becomes involved in, or is threatened with, litigation with a subcontractor or vendor as a result of such direction. The contractor may request the United States to enter into such litigation to protect the interests of the United States.

3.8 EQUAL EMPLOYMENT OPPORTUNITY CLAUSE

(Incorporated by Reference)

The Equal Employment Opportunity Clause required under Executive Order 11246, the affirmative action commitment for disabled veterans and veterans of the Vietnam era, set forth in 41 CFR 60-250.4 the affirmative action clause for handicapped workers, set forth in 40 CFR 60-741.4 and the related regulations of the Secretary of Labor. 40 CFR Chapter 60, are incorporated by reference in this purchase order. By accepting this purchase order, vendor certifies that it complies with the authorities cited above, and that it does not maintain segregated facilities or permit its employees to perform services at locations where segregated facilities are maintained, as required by 41 CFR 60-1.8

3.9 ANTI-KICKBACK ACT

NOTICE TO CONTRACTORS: The Contractor shall comply with the applicable regulations of the Secretary of Labor, United States Department of Labor, made pursuant to the Copeland Anti-Kickback Act (Title 40 U.S.C., Section 276c), and any amendment or modifications thereof, shall cause appropriate provisions to be inserted in subcontracts to insure compliance therewith by all subcontractors subject thereto, and shall be responsible for the submission of affidavits required by subcontractor thereunder, except as said Secretary of Labor may specifically provide for reasonable limitations, variations, tolerance, and exemptions from the requirements thereof.

Copeland “Anti-Kickback” Act Policy

The Copeland “Anti-Kickback” Act prohibits contractors or subcontractors engaged in building construction or repair from persuading an employee to give up any part of the compensation to which he or she is entitled under his or her employment contract.

NOTICE TO MUNICIPAL EMPLOYEES: *Any employee who offers or approves the offer of a business consideration must ensure that it is ethical and proper in all respects. The offer of a business consideration cannot reasonably be interpreted as an attempt to gain an unfair business advantage or otherwise reflect negatively on the reputation of the City of Muskegon and/or the recipient. The business consideration shall not violate this anti-kickback policy.*

The City of Muskegon’s (Muskegon) staff, representatives, and contractors are prohibited from receiving unreasonable compensation from grantors, grantees, contractors, applicants, or any other person or individual for the purpose of receiving preferential treatment of any kind. The guidelines below define Muskegon’s policy toward kickbacks and the penalties for offering kickbacks to Muskegon employees, representatives or contractors.

Definition: “Kickback” for the purposes of this policy (excluding de minimis gifts), means substantial money, fees, commission, gifts, gratuity, object of value, or offer of employment, which is provided or offered, directly or indirectly, to any City of Muskegon employee, contractor or contracted employee, vendor or vendor employee, or consultant for the purpose of improperly obtaining or rewarding favorable treatment in connection with a City of Muskegon project or contract.

This policy prohibits any person or organization from:

Providing or attempting to provide or offering to provide kickbacks;
Soliciting, accepting or attempting to accept kickbacks; or
Including, directly or indirectly, the amount of kickbacks in any contract awarded by City of Muskegon, contractors, or subcontractors.

Any employee found to be in violation of this policy will be subject to an investigation by the City of Muskegon’s Compliance Officer to determine if the policy was infringed upon.

Depending on the results of the investigation, appropriate discipline will be determined. The employee may be subject to civil or criminal penalties as provided under U.S. law.

Any applicant, grantee, contractor, consultant, or vendor in violation of this policy will be prohibited from participation in any City of Muskegon project, contract, or activity and may be subject to additional civil or criminal penalties as provided under U.S. law (Title 40 U.S.C., Section 276c).

Muskegon reserves the right to recover damages from any person who knowingly engages in such prohibited conduct and from any person whose employee, contractor, or subcontracted employee provides, accepts, or charges a kickback.

SECTION 4

3.10 PREVAILING WAGE DECISION

THIS IS NOT A PREVAILING WAGE PROJECT

PART 4 – CITY OF MUSKEGON ENGINEERING SPECIFICATIONS

The City of Muskegon Standard Construction Specification can be found on our web site, link below. It is the Contractors responsibility to download and review these specifications before bidding.

<https://muskegon-mi.gov/city-services/public-works/engineering/>

PART 5 – SPECIAL SPECIFICATIONS

FOR ALL PAY ITEMS

All pay items shall be constructed as specified in the Michigan Department of Transportation 2020 Standard Specifications for Construction, Michigan Department of Transportation Standard Plans, and the City of Muskegon Standard Specifications for Watermain except where modified in these Special Specifications. Materials for all pay items shall meet the specifications as specified in the Michigan Department of Transportation 2020 Standard Specifications for Construction, Michigan Department of Transportation Standard Plans, and The City of Muskegon Standard Specifications for Watermain except where modified in these Special Specifications.

LIQUIDATED DAMAGES; TIME OF THE ESSENCE

The work will not start until after contractor receives Notice to Proceed.

Liquidated Damages will be in compliance with the Progress Clause contained in these Special Specifications.

PROGRESS CLAUSE

1 of 1

The City of Muskegon anticipates that construction can begin no earlier than July 1, 2024. In no case shall any work be commenced prior to receipt of formal Notice of Award of Contract from the Department.

The Contractor shall prepare and submit a complete, detailed, and signed Progress Schedule to the Engineer.

The project shall be Open to Traffic on or before November 15, 2024.
The entire project (both streets) shall be completed on or before December 1, 2024.

Once started, New Street shall be completed within in 8 weeks from the start date.
Once started, 2nd Street shall be completed within 6 weeks from the start date.

After award and prior to the start of work, the Contractor must attend a preconstruction meeting. The Engineer will determine the day, time and place for the preconstruction meeting. The meeting will be conducted after project award and may be rescheduled if there are delays in the award of the project.

The named subcontractor(s) for Designated and/or Specialty Items, as shown in the Proposal, should attend the preconstruction meeting if such items materially affect the work schedule.

Liquidated Damages shall be assessed in accordance with Section 108.10 of the MDOT 2020 Standard Specifications for Construction.

UTILITY COORDINATION

The contractor shall cooperate and coordinate construction activities with the owners of utilities as stated in Section 104.08 of the 2020 MDOT Standard Specifications for Construction. In addition, for the protection of underground utilities, the contractor shall follow the requirements in section 107.12 of the 2020 MDOT Standard Specifications for Construction. Contractor delay claims, resulting from a utility, will be determined based upon Section 108.09 of the 2020 MDOT Standard Specifications for Construction.

Public Utilities

The following Public Utilities have facilities located within the Right-of-Way:

Consumers Energy – Joel Brown
700 E Sternberg Road
Norton Shores Mi, 49441
phone: (231) 332-2682

Frontier Communications. – Cindy Whiteman
860 Terrace Street
Muskegon, Michigan 49440
phone: (231) 727-1134

DTE Energy – Raymond Shetterly
2359 Olthoff Drive
Muskegon, Michigan 49444
phone: (231) 777-4049; cell 231-730-5441

Comcast – Jonathan Charland
700 W. Broadway Avenue
Muskegon Heights Mi 49444
phone: (810) 217-1642

City of Muskegon Department of Public Works & Utilities
1350 E. Keating Avenue
Muskegon, Michigan 49442
phone: (231) 724-4100

Western Tel-Com, Inc – Eric Merrifield
(For Muskegon Area Intermediate School District)
A-4273 Blue Star Highway P.O. Box 1317
Holland, Michigan 49422
phone: (616) 393-0138 ext. 125

On all Projects: **"three working days before you dig - Call Miss Dig - Toll Free"....811.** The owners of existing service facilities that are within grading or structure limits will move them to locations designated by the Engineer or will remove them entirely from the highway Right-of-Way. Owners of Public Utilities will not be required by the County/City to move additional poles or structures in order to facilitate the operation of construction equipment unless it is determined by the Engineer that such poles or structures constitute a hazard to the public or are extraordinarily dangerous to the contractor's operations.

**CITY OF MUSKEGON
SPECIAL PROVISION
FOR
DR STRUCTURE, REM, MODIFIED**

February 2022

1 of 1

City of Muskegon

DESCRIPTION

The work covered by this special provision shall be in accordance with Section 203 of the MDOT 2020 Standard Specifications for Construction.

CONSTRUCTION METHODS

The work covered by this special provision shall be in accordance with the applicable requirements in Section 203 of the MDOT 2020 Standard Specifications for Construction except for the following:

All manholes, catch basins, including water valve manholes, shall be removed in full including footings.

No masonry from the structure will be allowed to be buried in the pavement area.

MEASUREMENT AND PAYMENT

The completed work including all materials, labor and equipment will be paid for at the contract unit price for the following contract item (pay item).

PAY ITEM

PAY UNIT

Dr Structure, Rem, Modified

Each

**CITY OF MUSKEGON
SPECIAL PROVISION
FOR
PAVT, REM, MODIFIED**

1 of 1

February 2022

City of Muskegon

DESCRIPTION

The work shall be in accordance with Section 204 of the MDOT 2020 Standard Specifications for Construction and as specified herein.

CONSTRUCTION

The work shall be in accordance with Section 204 of the MDOT 2020 Standard Specifications for Construction, except for the following:

Saw-cut edge as indicated on the plans or as directed by the Engineer and remove the full depth of pavement, regardless of thickness or the material.

Pavement cores and soil boring logs are shown on the construction plans. The Contractor is responsible for verification of this data before bidding on this project.

MEASUREMENT AND PAYMENT

Pavt, Rem, Modified will be measured and paid for once regardless of the existing material type, number of layers or thickness of individual layers. The completed work including all materials, labor and equipment will be measured and paid for at the contract unit price for the following contract item (pay item):

PAY ITEM

Pavt, Rem, Modified

PAY UNIT

Square Yard

**CITY OF MUSKEGON
SPECIAL PROVISION
FOR
MACHINE GRADING, MODIFIED**

1 of 2

May 2024

City of Muskegon

DESCRIPTION:

The work covered by this special provision shall be in accordance with Section 205 of the MDOT 2020 Standard Specifications for Construction, except where modified herein.

CONSTRUCTION METHODS:

New Street:

Under the Machine Grading, Modified pay item contractor shall remove approximately 3358 cubic yards of the existing sand and aggregate base from station 0+90 to 22+20. The resulting sub base shall be shaped to within 0.5 inch of the proposed cross section as shown on the construction plans. The existing new base will be watered and compacted to 95% of the maximum unit weight.

All excess excavated material (sand and aggregate) shall become the property of the contractor. Payment for removing the excavation, placing embankment, compacting subgrade, shaping subgrade and removing excess material will be included in payment for the Machine Grading, Modified pay item. Embankment shall meet Granular Material Class II specifications.

From station 0+90 TO 5+00 there is approximately 650 cubic yards of excavation.
From station 5+00 TO 10+00 there is approximately 809 cubic yards of excavation.
From station 10+00 TO 15+00 there is approximately 834 cubic yards of excavation.
From station 15+00 TO 22+20 there is approximately 1065 cubic yards of excavation.

2nd Street:

Under the Machine Grading, Modified pay item contractor shall remove approximately 506 cubic yards of the existing sand and aggregate base from station 0+97 to 2+29/9+79 to 14+40. The resulting sub base shall be shaped to within 0.5 inch of the proposed cross section as shown on sheets 2 of the construction plans. The existing new base will be watered and compacted to 95% of the maximum unit weight.

All excess excavated material (sand and aggregate) shall become the property of the contractor. There will be approximately 506 cubic yards of excavation, of which 31 cubic yards will be used as embankment. The remaining 475 cubic yards of excavation will be removed from the job site and become the property of the contractor. Payment for removing the excavation, placing embankment, compacting subgrade, shaping subgrade and removing excess material will be included in payment for the Machine Grading, Modified pay item. Embankment shall meet Granular Material Class II specifications.

MACHINE GRADING, MODIFIED

2 of 2

From station 0+97 TO 2+29 there is approximately 151 cubic yards of excavation.
From station 9+79 to 14+40 there is approximately 355 cubic yards of excavation.

The City can provide electronic Auto cad file for the use of automated machine guidance. These electronic files are not construction documents. Differences may exist between these electronic files and corresponding hard-copy construction documents. Engineer makes no representation regarding the accuracy or completeness of the electronic files. In the event that a conflict arises between the hard-copy drawings and the electronic files, the hard-copy drawings shall govern. Contractor is responsible for determining if any conflicts exist. No additional compensation will be paid for errors found within the electronic files.

MEASUREMENT AND PAYMENT:

Measurement will be by length in stations measured once along the proposed road centerline.

The completed work including all materials, labor and equipment will be measured and paid for at the contract unit price for the following:

<u>Pay Item:</u>	<u>Pay Unit:</u>
Machine Grading, Modified	Station

**CITY OF MUSKEGON
SPECIAL PROVISION
FOR
SEWER, DUCTILE IRON CL 52, __ INCH TR DET B**

1 of 1

February 2022

City of Muskegon

DESCRIPTION

The work covered by this special provision shall be in accordance with Section 402 of the MDOT 2020 Standard Specifications for Construction.

MATERIALS

Sewer shall be ductile cast iron and conform to AWWA Specification C151 where called out on the construction plans. The sewer shall be cement lined standard thickness and shall have Push-on Joints. Joints shall conform to AWWA Specification C151. Thickness Class 52 shall be used on all Ductile Iron Sewer.

Backfill material shall meet the grading requirements for Granular Class II.

CONSTRUCTION

The work covered by this special provision shall be in accordance with the applicable requirements in Section 402 of the MDOT 2020 Standard Specifications for Construction.

MEASUREMENT AND PAYMENT

The completed work including all materials, labor and equipment, as measured will be paid for at the contract unit price for the following contract items (pay items).

PAY ITEM

PAY UNIT

Sewer, Ductile Iron CL 52, __ Inch, Tr Det B

Foot

**CITY OF MUSKEGON
SPECIAL PROVISION
FOR
CATCH BASIN, __ DIA, SPECIAL DETAIL**

1 of 1

April 2022

City of Muskegon

DESCRIPTION

The work shall be in accordance with Section 403 of the MDOT 2020 Standard Specifications for Construction.

MATERIALS

Structure shall be precast meeting ASTM C478 unless approved by the Engineer to use brick and/or block.

Concrete footing shall be Grade 3500 meeting 3500 psi concrete compressive strength in 28 days.

Brick shall be ASTM C-139 Lime Cement, laid radially.

Holes for pipe openings shall not be less than 2 inches or more than 6 inches larger than the outside diameter of the pipe and shall be filled with non-shrink mortar.

Joints shall be O-ring rubber gasket joints meeting ASTM C443.

Backfill material shall meet the grading requirements for Granular Class II.

CONSTRUCTION

The work shall be in accordance with the requirements of Section 403 of the MDOT 2020 Standard Specifications for Construction, the Detail for Catch Basin, 2 Ft Dia Special Detail and Catch Basin 4 Ft Dia Special Detail on the construction plans.

MEASUREMENT AND PAYMENT

The completed work including all materials, labor and equipment, will be measured and paid for at the contract unit price for the following contract item (pay item).

<u>PAY ITEM</u>	<u>PAY UNIT</u>
Catch Basin, 2 Ft DIA, Special Detail	Each
Catch Basin, 4 Ft DIA, Special Detail	Each

**CITY OF MUSKEGON
SPECIAL PROVISION
FOR
DR STRUCTURE COVER, TYPE __, MODIFIED**

1 of 2

September 2021

City of Muskegon

DESCRIPTION

The work shall be in accordance with Section 403 of the MDOT 2020 Standard Specifications for Construction, except where modified herein.

MATERIALS

On this project, the following drainage structure covers will be used:

Dr Structure Cover, Type B, Modified shall conform to EJ Manhole Casting #1045 or approved by engineer (330 lbs each). Castings shall have the City of Muskegon Logo cast into them according to the detail on page 2 of this special provision.

Dr Structure Cover, Type D, Modified shall conform to Flat style Catch Basin casting East Jordan #5105 or equal (435 lbs. each)

Dr Structure Cover, Type K, Modified shall conform to EJ Curb Inlet Casting Catch Basin casting #7045 or approved by engineer (490 lbs. each).

CONSTRUCTION

The work in accordance with the requirements in Section 403 of the MDOT 2020 Standard Specifications for Construction.

MEASUREMENT AND PAYMENT:

The completed work including all materials, labor and equipment, will be measured and paid for at the contract unit price for the following contract item (pay item).

PAY ITEM

PAY UNIT

Dr Structure Cover, Type __, Modified

Each

**CITY OF MUSKEGON
SPECIAL PROVISION
FOR
DR STRUCTURE COVER, TYPE B, MODIFIED**

City of Muskegon

Page 2 of 2

January 22, 2010

1040 A LOGO MANHOLE COVER

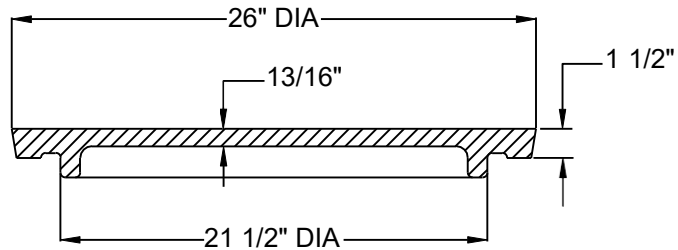
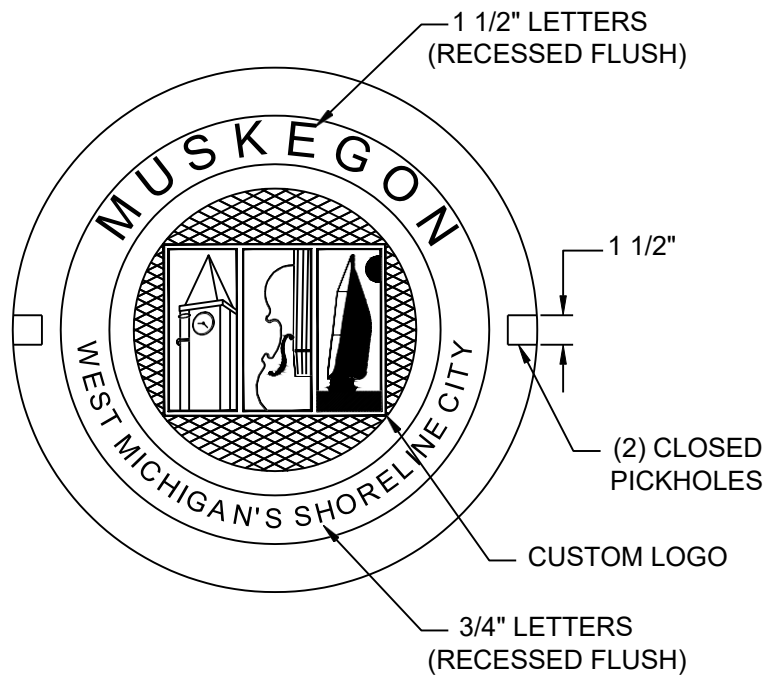

COVER SECTION

**CITY OF MUSKEGON
SPECIAL PROVISION
FOR
DR STRUCTURE, ADJ, ADD DEPTH, MODIFIED**

1 of 1

April 2022

City of Muskegon

DESCRIPTION

The work covered by this special provision shall be in accordance with Section 403 of the MDOT 2020 Standard Specifications for Construction.

MATERIALS

The materials shall meet the requirements specified in Section 403 of the MDOT 2020 Standard Specifications for Construction except as modified herein.

CONSTRUCTION

The work covered by this special provision shall be in accordance with the applicable requirements in Section 403 of the MDOT 2020 Standard Specifications for Construction and shall also include the following:

When called for on construction plans “Drainage Structure, Adj, Add Depth, Modified” is equal to or greater than two feet the contractor will use precast eccentric cone sections conforming to ASTM C-478 or a precast reinforced concrete flat slab top to reconstruct the existing structure as indicated on plans. Brick or block will not be allowed to reconstruct drainage structures where the depth of reconstruction is equal to or more than 2 feet unless authorized by the engineer.

MEASUREMENT & PAYMENT

The completed work including all materials, labor, and equipment will be measured and paid for at the contract unit price for the following contract item (pay item).

PAY ITEM

PAY UNIT

Dr Structure, Adj, Add Depth, Modified

Foot

**CITY OF MUSKEGON
SPECIAL PROVISION
FOR
DR STRUCTURE COVER, ADJ, CASE I, MODIFIED**

1 of 1

September 2021

City of Muskegon

DESCRIPTION

The work shall be in accordance with Section 403 of the 2020 MDOT Standard Specifications for Construction.

MATERIALS

The materials shall meet the requirements specified in Section 403.02 of the 2020 MDOT Standard Specifications for Construction.

CONSTRUCTION

The work shall be in accordance with the requirements in Section 403.03 of the 2020 MDOT Standard Specifications for Construction and shall also include the following:

Drainage Structure, Temporary Lowering will be included in pay item Dr Structure Cover, Adj, Case I, Modified. No payment for Dr Structure, Temporary Lowering will be allowed for the work of removing existing castings and steel plating of the drainage structure holes. This work will be included in the payment for Dr Structure Cover, Adj, Case I, Modified

Replacement of pavement adjacent to the adjusted cover shall be constructed according to the detail shown on the construction plans.

Payment includes adjusting the cover up or down, a maximum of 6 inches, to the required elevation.

Finish grade of covers will be inspected for ride quality. Covers will be checked by laying a 6 foot straight edge on the finished pavement and measuring to the cover. Covers that vary from finish pavement grade by ½ inch or more will have to be readjusted by the contractor at no cost to the City of Muskegon. Contractor will be required to saw cut a square of 4 foot X 4 foot centered on the cover, remove the pavement and cover, adjust the cover to finished pavement grade, and replace the excavated pavement with 10 inches of concrete pavement.

MEASUREMENT & PAYMENT

The completed work including all materials, labor, and equipment will be measured and paid at the contract unit price for the following contract item (pay item).

PAY ITEM

PAY UNIT

Dr Structure Cover, Adj, Case 1, Modified

Each

**CITY OF MUSKEGON
SPECIAL PROVISION FOR
ACCEPTANCE OF HOT MIX ASPHALT MIXTURE ON LOCAL AGENCY PROJECTS**

City of Muskegon

Description.

This special provision provides sampling and testing requirements for local agency projects using the roller method and the nuclear density gauge testing. Provide the hot mix asphalt (HMA) mixture in accordance with the requirements of the standard specifications, except where modified herein.

Materials.

Provide aggregates, mineral filler (if required), and asphalt binder to produce a mixture proportioned within the master gradation limits shown in the contract, and meeting the uniformity tolerance limits in Table 1.

Table 1: Uniformity Tolerance Limits for HMA Mixtures

Parameter		Top and Leveling Course		Base Course		
Number	Description	Range 1 (a)	Range 2	Range 1 (a)	Range 2	
1	% Binder Content	-0.30 to +0.40	±0.50	-0.30 to +0.40	±0.50	
2	% Passing	# 8 and Larger Sieves	±5.0	±8.0	±7.0	±9.0
		# 30 Sieve	±4.0	±6.0	±6.0	±9.0
		# 200 Sieve	±1.0	±2.0	±2.0	±3.0
3	Crushed Particle Content (b)	Below 10%	Below 15%	Below 10%	Below 15%	
This range allows for normal mixture and testing variations. The mixture must be proportioned to test as closely as possible to the Job-Mix-Formula (JMF). Deviation from JMF.						

Parameter number 2 as shown in Table 1 is aggregate gradation. Each sieve will be evaluated on one of the three gradation tolerance categories. If more than one sieve is exceeding Range 1 or Range 2 tolerances, only the one with the largest exceedance will be counted as the gradation parameter.

The master gradation should be maintained throughout production; however, price adjustments will be based on Table 1. Aggregates which are to be used in plant-mixed HMA mixtures must not contain topsoil, clay, or loam.

Construction. Submit a Mix Design and a JMF to the Engineer. Do not begin production and placement of the HMA until receipt of the Engineer's approval of the JMF. Maintain the binder content, aggregate gradation, and the crushed particle content of the HMA mixture within the Range 1 uniformity tolerance limits in Table 1. For mixtures meeting the definition of top or leveling course, field regress air void content to 3.5 percent with liquid asphalt cement unless

specified otherwise on HMA application estimate. For mixtures meeting the definition of base course, field regress air void content to 3.0 percent with liquid asphalt cement unless specified otherwise on HMA application estimate.

Ensure all persons performing Quality Control (QC) and Quality Assurance (QA) HMA field sampling are "Local Agency HMA Sampling Qualified" samplers. At the Pre-Production or Pre-Construction meeting, the Engineer will determine the method of sampling to be used. Ensure all sampling is done in accordance with MTM 313 (Sampling HMA Paving Mixtures) or MTM 324 (Sampling HMA Paving Mixtures Behind the Paver). Samples are to be taken from separate hauling loads.

For production/mainline type paving, obtain a minimum of two samples, each being 20,000 grams, each day of production, for each mix type. The Engineer will sample and maintain possession of the sample. Sampling from the paver hopper is prohibited. Each sample will be divided into two 10,000 gram parts with one part being for initial testing and the other part being held for possible dispute resolution testing. Obtain a minimum of three samples for each mix type regardless of the number of days of production.

Obtain samples that are representative of the day's paving. Sample collection is to be spaced throughout the planned tonnage. One sample will be obtained in the first half of the tonnage and the second sample will be obtained in the second half of the tonnage. If planned paving is reduced or suspended, when paving resumes, the remaining sampling must be representative of the original intended sampling timing.

Ensure all persons performing testing are Bit Level One certified or Bit QA/QC Technician certified.

Ensure daily test samples are obtained, except, if the first test results show that the HMA mixture is in specification, the Engineer has the option of not testing additional samples from that day.

At the Pre-Production or Pre-Construction meeting, the Engineer and Contractor will collectively determine the test method for measuring asphalt content (AC) using MTM 319 (Determination of Asphalt Content from Asphalt Paving Mixtures by the Ignition Method) or MTM 325 (Quantitative Extraction of Bitumen from HMA Paving Mixtures). Back calculation will not be allowed for determining asphalt content.

Ensure all labs performing local agency acceptance testing are qualified labs per the HMA Production Manual and participate in the MDOT round robin process, or they must be AASHTO Materials Reference Laboratory (AMRL) accredited for AASHTO T 30 or T 27, and AASHTO T 164 or T 308. Ensure on non-National Highway System (NHS) routes, Contractor labs are made available, and may be used, but they must be qualified labs as previously stated. Contractor labs may not be used on NHS routes. Material acceptance testing will be completed by the Engineer within 14 calendar days, except holidays and Sundays, for projects with less than 5,000 tons (plan quantity) of HMA and within 7 calendars days, except holidays and Sundays, for projects with 5,000 tons (plan quantity) or more of HMA, after the Engineer has obtained the samples. QA test results will be provided to the Contractor after the Engineer receives the QC test results. Failure on the part of the Engineer or the laboratory to provide Quality Assurance test results within the specified time frame does not relieve the Contractor of their responsibility to provide an asphalt mix within specifications.

The correlation procedure for ignition oven will be established as follows. Asphalt binder content based on ignition method from MTM 319. Gradation (ASTM D 5444) and Crushed particle content (MTM 117) based on aggregate from MTM 319. The incineration temperature will be established at the Pre-Production Meeting. The Contractor will provide a laboratory mixture sample to the acceptance laboratory to establish the correction factor for each mix. Ensure this sample is provided to the Engineer a minimum of 14 calendar days prior to production.

For production/mainline type paving, the mixture may be accepted by visual inspection up to a quantity of 500 tons per mixture type, per project (not per day). For non-production type paving defined as driveways, approaches, and patching, visual inspection may be allowed regardless of the tonnage.

The mixture will be considered out-of-specification, as determined by the acceptance tests, if for any one mixture, two consecutive tests per parameter, (for Parameter 2, two consecutive aggregate gradations on one sieve) are outside Range 1 or Range 2 tolerance limits. If a parameter is outside of Range 1 tolerance limits and the second consecutive test shows that the parameter is outside of Range 2, then it will be considered to be a Range 1 out-of-specification. Consecutive refers to the production order and not necessarily the testing order. Out-of-specification mixtures are subject to a price adjustment per the Measurement and Payment section of this special provision.

Contractor operations will be suspended when the mixture is determined to be out-of-specification, but contract time will continue to run. The Engineer may issue a Notice of Non-Compliance with Contract Requirements (Form 1165), if the Contractor has not suspended operations and taken corrective action. Submit a revised JMF or proposed alterations to the plant and/or materials to achieve the JMF to the Engineer. Effects on the Aggregate Wear Index (AWI) and mix design properties will be taken into consideration. Production and placement cannot resume until receipt of the Engineer's approval to proceed.

Pavement in-place density will be measured using one of two approved methods. The method used for measuring in-place density will be agreed upon at a pre-production or pre-construction meeting.

Pavement in-place density tests will be completed by the Engineer during paving operations and prior to traffic staging changes. Pavement in-place density acceptance testing will be completed by the Engineer prior to paving of subsequent lifts and being open to traffic.

Option 1 – Direct Density Method

Use of a nuclear density gauge requires measuring the pavement density using the Gmm from the JMF for the density control target. The required in-place density of the HMA mixture must be 92.0 to 98.0 percent of the density control target. Nuclear density testing and frequency will be in accordance with the MDOT Density Testing and Inspection Manual.

Option 2 – Roller Method

The Engineer may use the Roller Method with a nuclear or non-nuclear density gauge to document achieving optimal density as discussed below.

Use of the density gauge requires establishing a rolling pattern that will achieve the required in-place density. The Engineer will measure pavement density with a density gauge using the Gmm from the JMF for the density control target.

Use of the Roller Method requires developing and establishing density frequency curves, and meeting the requirements of Table 2. A density frequency curve is defined as the measurement and documentation of each pass of the finished roller until the in-place density results indicate a decrease in value. The previous recording will be deemed the optimal density. The Contractor is responsible for establishing and documenting an initial or QC rolling pattern that achieves the optimal in-place density. When the density frequency curve is used, the Engineer will run and document the density frequency curve for each half day of production to determine the number of passes to achieve the maximum density. Table 5, located at the end of this special provision, can be used as an aid in developing the density frequency curve. The Engineer will perform density tests using an approved nuclear or non-nuclear gauge per the manufacturer’s recommended procedures.

Table 2: Minimum Number of Rollers Recommended Based on Placement Rate

Average Laydown Rate, Square Yards per Hour	Number of Rollers Required (a)	
	Compaction	Finish
Less than 600	1	1 (b)
601 - 1200	1	1
1201 - 2400	2	1
2401 - 3600	3	1
3601 and More	4	1
Number of rollers may increase based on density frequency curve. The compaction roller may be used as the finish roller also.		

After placement, roll the HMA mixture as soon after placement as the roller is able to bear without undue displacement or cracking. Start rolling longitudinally at the sides of the lanes and proceed toward the center of the pavement, overlapping on successive trips by at least half the width of the drum. Ensure each required roller is 8 tons minimum in weight unless otherwise approved by the Engineer.

Ensure the initial breakdown roller is capable of vibratory compaction and is a maximum of 500 feet behind the paving operations. The maximum allowable speed of each roller is 3 miles per hour (mph) or 4.5 feet per second. Ensure all compaction rollers complete a minimum of two complete rolling cycles prior to the mat temperature cooling to 180 degrees Fahrenheit (F). Continue finish rolling until all roller marks are eliminated and no further compaction is possible. The Engineer will verify and document that the roller pattern has been adhered to. The Engineer can stop production when the roller pattern is not adhered to.

Measurement and Payment. The completed work, as described, will be measured and paid for using applicable pay items as described in subsection 501.04 of the Standard Specifications for Construction, or the contract, except as modified below.

Base Price. Price established by the Department to be used in calculating incentives and adjustments to pay items and shown in the contract.

If acceptance tests, as described in section c. of this special provision, show that a Table 1 mixture parameter exceeds the Range 1, but not the Range 2, tolerance limits, that mixture parameter will be subject to a 10 percent penalty. The 10 percent penalty will be assessed based on the acceptance tests only unless the Contractor requests that the 10,000 gram sample part retained for possible dispute resolution testing be tested. The Contractor has 4 calendar days from receipt of the acceptance test results to notify the Engineer, in writing, that dispute resolution testing is requested. The Contractor's QC test results for the corresponding QA test results must result in an overall payment greater than QA test results otherwise the QA tests will not be allowed to be disputed. The Engineer has 4 calendar days to send the dispute resolution sample to the lab once dispute resolution testing is requested. The dispute resolution sample will be sent to an independent lab selected by the Local Agency, and the resultant dispute test results will be used to determine the penalty per parameter, if any. Ensure the independent lab is a MDOT QA/QC qualified lab or an AMRL HMA qualified lab. The independent lab must not have conflicts of interest with the Contractor or Local Agency. If the dispute testing results show that the mixture parameter is out-of-specification, the Contractor will pay for the cost of the dispute resolution testing and the contract base price for the material will be adjusted, based on all test result parameters from the dispute tests, as shown in Table 3 and Table 4. If the dispute test results do not confirm the mixture parameter is out-of-specification, then the Local Agency will pay for the cost of the dispute resolution testing and no price adjustment is required.

If acceptance tests, as described in section c. of this special provision, show that a Table 1 mixture parameter exceeds the Range 2 tolerance limits, the 10,000 gram sample part retained for possible dispute resolution testing will be sent, within 4 calendar days, to the MDOT Central Laboratory for further testing. The MDOT Central Laboratory's test results will be used to determine the penalty per mixture parameter, if any. If the MDOT Central Laboratory's results do not confirm the mixture parameter is out-of-specification, then no price adjustment is required. If the MDOT Central Laboratory's results show that the mixture is out-of-specification and the Engineer approves leaving the out-of-specification mixture in place, the contract base price for the material will be adjusted, based on all parameters, as shown in Table 3 and Table 4.

In the case that the Contractor disputes the results of the test of the second sample obtained for a particular day of production, the test turn-around time frames given would apply to the second test and there would be no time frame on the first test.

The laboratory (MDOT Central Laboratory or independent lab) will complete all Dispute Resolution testing and return test results to the Engineer, who will provide them to the Contractor, within 13 calendar days upon receiving the Dispute Resolution samples.

In all cases, when penalties are assessed, the penalty applies to each parameter, up to two parameters, that is out of specification.

Table 3: Penalty Per Parameter

Mixture Parameter out-of-Specification per Acceptance Tests	Mixture Parameter out-of-Specification per Dispute Resolution Test Lab	Price Adjustment per Parameter
NO	N/A	None
YES	NO	None
	YES	Outside Range 1 but not Range 2: decrease by 10% Outside Range 2: decrease by 25%

The quantity of material receiving a price adjustment is defined as the material produced from the time the first out-of-specification sample was taken until the time the sample leading to the first in-specification test was taken.

Each parameter of Table 1 is evaluated with the total price adjustment applied to the contract base price based on a sum of the two parameter penalties resulting in the highest total price adjustment as per Table 4. For example, if three parameters are out-of-specification, with two parameters outside Range 1 of Table 1 tolerance limits, but within Range 2 of Table 1 limits and one parameter outside of Range 2 of Table 1 tolerance limits and the Engineer approves leaving the mixture in place, the total price adjustment for that quantity of material is 35 percent.

Table 4: Calculating Total Price Adjustment

Cost Adjustment as a Sum of the Two Highest Parameter Penalties		
Number of Parameters Out-of-Specification	Range(s) Outside of Tolerance Limits of Table 1 per Parameter	Total Price Adjustment
One	Range 1	10%
	Range 2	25%
Two	Range 1 & Range 1	20%
	Range 1 & Range 2	35%
	Range 2 & Range 2	50%
Three	Range 1, Range 1 & Range 1	20%
	Range 1, Range 1 & Range 2	35%
	Range 1, Range 2 & Range 2	50%
	Range 2, Range 2 & Range 2	50%

Table 5: Density Frequency Curve Development

Tested by: _____ Date/Time: _____

Route/Location:		Air Temp:
Control Section/Job Number:		Weather:
Mix Type:	Tonnage:	Gauge:
Producer:	Depth:	Gmm:

Roller #1 Type: _____

Pass No.	Density	Temperature	Comments
1			
2			
3			
4			
5			
6			
7			
8			
Optimum			

Roller #2 Type: _____

Pass No.	Density	Temperature	Comments
1			
2			
3			
4			
5			
6			
7			
8			
Optimum			

Roller #3 Type: _____

Pass No.	Density	Temperature	Comments
1			
2			
3			
4			
5			
6			
7			
8			
Optimum			

Summary:

**CITY OF MUSKEGON
SPECIAL PROVISION
FOR
DRIVEWAY, NONREINF CONC, __ INCH, MODIFIED**

1 of 1

February 2022

City of Muskegon

DESCRIPTION

The work covered by this special provision shall be in accordance with Section 801 of the MDOT 2020 Standard Specifications for Construction except where modified herein.

MATERIALS

The materials shall meet the requirements specified in Sections 901, 902 and 903 of the MDOT 2020 Standard Specifications for Construction.

CONSTRUCTION METHODS

The work covered by this special provision shall be in accordance with the applicable requirements in Section 801 of the MDOT 2020 Standard Specifications for Construction except for the following: The Contractor shall construct the Driveway, Nonreinf Conc, __ inch, Modified as directed on the details within construction plans.

MEASUREMENT AND PAYMENT

The completed work including all materials, labor and equipment, as measured will be paid for at the contract unit price for the following contract item (pay item).

PAY ITEM

PAY UNIT

Driveway, Nonreinf Conc, __ inch, Modified

Square Yard

**CITY OF MUSKEGON
SPECIAL PROVISION
FOR
CURB and GUTTER, CONC, DET __, MODIFIED**

1 of 1

April 2024

City of Muskegon

DESCRIPTION

The work covered by this special provision shall be in accordance with Section 802 of the MDOT 2020 Standard Specifications for Construction, except where modified herein.

MATERIALS

The materials shall meet the requirements specified in Sections 901, 902, 903 of the MDOT 2020 Standard Specifications for Construction.

CONSTRUCTION METHODS

The work covered by this special provision shall be in accordance with the applicable requirements in Section 802 except for the following: Expansion material of 1-inch fiber shall be placed at 100 ft intervals, the point of curvature (PC), the point of tangency (PT), and 10 ft. to 20 ft each side of catch basins, or as directed by the Engineer. In addition, payment for Curb and Gutter, Conc, Det __, Modified shall include the aggregate base under the curb and gutter, as shown on the Typical Proposed Cross Sections on the construction plans.

MEASUREMENT AND PAYMENT

The completed work including all materials, labor and equipment, as measured will be paid for at the contract unit price for the following contract item (pay item).

PAY ITEM

PAY UNIT

Curb and Gutter, Conc, Det __, Modified

Foot

**CITY OF MUSKEGON
SPECIAL PROVISION
FOR
MAINTAINING TRAFFIC**

1 of 2

May 2022

City of Muskegon

DESCRIPTION

This special provision consists of requirements and restrictions to maintain traffic.

GENERAL

This work shall be in accordance with the requirements of the 2020 MDOT Standard Specifications for Construction and as herein specified. The Contractor is advised that the 2011 Michigan Manual of Uniform Traffic Control Devices is hereby established as governing all work in connection with traffic control devices, barricade lighting, etc., required for this project.

Walks, driveways, and entrances to buildings shall not be unnecessarily blocked. Vehicular access shall be maintained to all properties designated by the Engineer. Protection for and protection of pedestrian traffic shall be maintained at all times.

Street name signs and stop signs in the way of construction will be removed and reset immediately in a temporary location. These signs shall finally be set by the Contractor in a location designated by the Engineer upon completion of final grading in the section involved. This work shall be included in payment for Minor Traf Devices.

SPECIFIC REQUIREMENTS

Traffic control devices shall be placed as shown on the construction plans. During construction, the contractor will be required to maintain access to businesses and residents.

TRAFFIC CONTROL DEVICES

All traffic control devices and their usage shall conform to the Michigan Manual of Uniform Traffic Control Devices (MMUTCD), 2011 edition as revised, and as specified herein.

During non-working periods, any work site with uncompleted work shall have advance Signs (W21-4 "Construction Ahead") and plastic drums, at specific locations, as directed by the Engineer, at no additional cost to the department.

At the completion of each work day, the contractor shall make sure that all property owners have access to their residences. The contractor shall also ensure that access for emergency vehicles is maintained.

MAINTAINING TRAFFIC

2 of 2

CONSTRUCTION INFLUENCE AREA (CIA)

The CIA shall include the right of way of the following roadways, within the approximate limits described below:

New Street from Evanston to Calvin.

Second St. from Houston Ave to Muskegon Ave, Houston Ave. (slip lane) from 2nd St. to Houston Ave.

TRAFFIC RESTRICTIONS

All work shall be conducted during daytime hours only. Night time work may be permitted, at the discretion of the Engineer, however, any additional cost for maintaining traffic and lighting shall be the responsibility of the Contractor.

TEMPORARY SIGNS

Construction signing for this project shall be as shown on construction plans. Distances shown between construction warning, regulatory and guide signs are shown approximate and may require field adjustment as directed by the Engineer.

TRAFFIC RESTRICTIONS

No work shall be performed during the following holiday periods, or as directed by the Engineer.

Memorial Day 2024	Starting Friday, May 24, 2024 at 3:00 PM through Tuesday, May 28, 2024 at 7:00 AM.
4 th of July 2024	Starting Tuesday, July 2, 2024 at 3:00 PM through Monday, July 8, 2024 at 7:00 AM.
Labor Day 2024	Starting Friday, August 30, 2024 at 3:00 PM through Tuesday, September 3, 2024 At 7:00 AM.

MEASUREMENT AND PAYMENT

Separate pay items are provided to compensate for Maintaining Traffic. All costs due to Maintaining Traffic are to be included with Minor Traf Devices.

Any additional signing or maintaining traffic devices required to expedite the construction shall be at the Contractor's expense.

**CITY OF MUSKEGON
SPECIAL PROVISION
FOR
MINOR TRAF DEVICES, MODIFIED
TRAF REGULATOR CONTROL, MODIFIED**

1 of 1

April 2024

City of Muskegon

DESCRIPTION

The work shall be in accordance with Section 812 of the MDOT 2020 Standard Specifications for Construction and as specified herein.

CONSTRUCTION

The work shall be in accordance with Section 812 of the MDOT 2020 Standard Specifications for Construction.

MEASUREMENT AND PAYMENT

Under Section 812.04E, add the following paragraph:

The Department will specify the maximum bid amount for **Minor Traf Devices and Traf Regulator**. If the contractor submits a bid amount that exceeds the maximum bid amount, the Department will use the maximum bid amount as the Contractors lump sum bid amount and will correct the total bid amount to reflect this maximum bid amount.

The maximum bid amount for **Minor Traf Devices** shall be **\$20,000.00**

The maximum bid amount for **Traf Regulator** shall be **\$5,000.00**

Under Section 812.04T, edit the third paragraph to read:

The Department will use Formula 812-1 to calculate the unit price adjustments. The adjustment for **Minor Traf Devices** will be at a daily rate of (A/B) not to exceed **\$300.00** per calendar or work day, and the adjustment for **Traf Regulator Control** will be at a daily rate of (A/B) not to exceed **\$150.00** per calendar or work day. When calculating the adjustment, either calendar or working days will be used for both original contract time and additional days.

The completed work including all materials, labor and equipment will be measured and paid for at the contract unit price for the following contract item (pay item):

PAY ITEM

PAY UNIT

Minor Traf Devices, Modified

Lump Sum

Traf Regulator, Modified

Lump Sum

**CITY OF MUSKEGON
SPECIAL PROVISION
FOR
HYDROSEEDING**

1 of 1

May 2022

City of Muskegon

DESCRIPTION

The work covered by this special provision shall be in accordance with Section 816 of the MDOT 2020 Standard Specifications for Construction.

CONSTRUCTION

The work covered by this special specification shall be in accordance with the applicable requirements in Section 816 of the MDOT 2020 Standard Specifications for Construction, except for the following:

This work shall consist of placing the seed by hydraulic means.

Seed type as specified, mulch, adhesive, and fertilizer shall be mixed in a solution of water and sprayed evenly over the ground area covered.

The Contractor shall use care spraying around signs, drives, sidewalk, and personal property. Excess material shall be rinsed promptly from these areas with clear water.

Application rates shall be the same as conventional methods:

Seeding – MDOT Class TUF seeding @ 220#/acre
Hydromulch - per manufacturer
Adhesive - per manufacturer
Fertilizer - Class A @ 228#/acre
Water - as necessary.

MEASUREMENT AND PAYMENT

The completed work including all materials, labor and equipment will be measured and paid for at the contract unit price for the following contract item (pay item).

PAY ITEM

PAY UNIT

Hydroseeding

Square Yard

**CITY OF MUSKEGON
SPECIAL PROVISION
FOR
WATER SERVICE __ INCH**

1 of 2

February 2022

City of Muskegon

DESCRIPTION

The work shall include replacing existing water services according to the detail on Construction Plans. In addition and included in the price of the new water service will be the abandonment of the existing service by turning off and disconnecting the existing water service from the existing watermain and removing any existing curb stops or water meter pits.

MATERIALS

The materials shall meet the following requirements:

CORPORATION (1 inch) – The 1 inch corporation shall be a Mueller #15000 (service connection flared) or Mueller #H15008 (conductive compression connection) or approved equal.

CORPORATION (2 inch) – The tap shall be done with a ductile iron saddle with stainless steel straps as manufactured by Smith-Blair Clamp and Coupling Products Taperseal No.317 or an approved equal and shall include the 2” Ford Ballcorp Corporation Stop no. FB 1000-7 or an approved equal.

CURB STOP AND BOX (1 inch) - The 1 inch curb stop shall be a Mueller #15157 or #15150 or approved equal with a 2 inch Minneapolis threaded top, bushed for 1.5 inch thread. The box shall be a Mueller #H10302 or approved equal, for 2 inch Minneapolis thread, bushed for 1.5 inch, complete with top.

CURB STOP AND BOX (2 inch) - Curb stops and boxes shall conform to City of Muskegon Standard Specifications Division 13.04.05 except the 2” curb stop shall be a Ford Ball Valve Curb Stop No. B44-777M or an approved equal. The curb stop box shall use a Minneapolis pattern with 2” x 1 ½” bushing to make a threaded connection to the 2” curb stop. Compression fittings with grounding clamps for two inch water services will be allowed.

WATER SERVICE PIPING - Water Service shall be constructed of Type "K" copper according to ASTM B88-55.

CONSTRUCTION

The __ inch water service shall be placed according to the detail on the construction plans. Abandonment of the existing service shall be included in the price of the new water service. Abandon the existing service by turning off the existing corporation, disconnecting the existing water service from the existing watermain and removing any existing curb stops or water meter pits.

City of Muskegon

DAMAGED EXISTING SERVICES: Water services, not scheduled for replacement, which have been cut or broken during construction, shall be repaired using type k copper. "Potential Lead Services" will require full replacement at the contract price or an agreed upon price. When dresser couplings are installed, the contractor shall attach a continuity wire, AGW size #4 copper to both sides of the dresser, properly secured with an approved grounding clamp. The circuit shall then be tested for continuity.

No payment shall be allowed for services cut or broken during construction, except when grade collisions are encountered. In these cases, the Contractor will reroute the service, as instructed by the Engineer, on a lump sum basis agreed to at the time.

MEASUREMENT AND PAYMENT:

The completed work, including all materials, labor and equipment will be measured and paid for at the contract unit price for the following contract items (pay items):

<u>PAY ITEM</u>	<u>PAY UNIT</u>
Corporation Stop, _ inch	Each
Curb Stop and Box, _ inch	Each
Water Service, _ inch, Copper Type K	Foot

Payment for all fittings to connect the existing water service to the new Water Service shall be included with payment for the water service material. Payment for abandonment of the existing service being replaced will be included in the payment for the new water service.

**CITY OF MUSKEGON
SPECIAL PROVISIONS
FOR
WATER SERVICE, PRIVATE PROPERTY**

1 of 4

February 2022

City of Muskegon

DESCRIPTION

It is the intent of the City of Muskegon to replace water services to a point within each building in accordance with EGLE guidelines. This specification shall be used for water service items beyond the curb stop or meter pit. Water services within the right of way (main to curb stop or meter pit) shall be installed according to City of Muskegon Standards for Construction, Division 13.

The work covered by this special specification shall be in accordance with the 2020 MDOT Standard Specifications for Construction, the City of Muskegon Standard Specifications, and current Michigan Plumbing Code, except where modifies herein. Any work on water services outside of the right of way may require plumbing permits from the inspections department. All work is to be in accordance to inspections department.

EXISTING PRIVATE FACILITIES

Existing wells, septic tanks, tile fields, lawn sprinklers or other facilities disturbed or damaged by the Contractor shall be repaired and restored to working condition before the end of that working day. Under no circumstances will such interruptions be extended overnight. The Contractor shall take necessary precautions not to allow any discharge from the above to enter any lake, stream or canal along the line of work. Costs for repairs or temporary service caused by the Contractor shall be at his own expense and no claims for extra work will be allowed.

All precautions necessary shall be taken to insure no damage occurs to homes, including basements.

MATERIALS

1. Water service pipe shall be 1-inch nominal diameter, Type K annealed, seamless copper manufactured in conformance with ASTM B88 specifications.

OR

2. Water service pipe shall be 1-inch nominal diameter, Crosslinked Polyethylene (PEX) Tubing manufactured in accordance with ANSI/AWWA C904, Crosslinked Polyethylene (PEX) Pressure Tubing, ½ -inch through 3-inch, for Water Service.
 - A. Tubing shall be certified by approved testing agencies.

City of Muskegon

- B. Tubing shall have a minimum chlorine resistance designation code of 1 as tested in accordance with ASTM F2023, Standard Test Method for Evaluating the Oxidative Resistance of Crosslinked Polyethylene (PEX) Tubing and Systems to Hot Chlorinated Water, as specified in ASTM F876, Standard Specification for Crosslinked Polyethylene (PEX) Tubing.
- C. Tubing shall have a minimum UV resistance designation code of 3 as tested in accordance with ASTM F2657, Standard Test Method for Outdoor Weathering Exposure of Crosslinked Polyethylene (PEX) Tubing.
- D. Tubing material HDB and HDS ratings shall be listed in accordance with procedures no less restrictive than those of PPIU TR-3, Policies and Procedures for Developing Hydrostatic Design Basis (HDB), Pressure Design Basis (PDB), Strength Design Basis (SDB), and Minimum Required Strength Design Basis (SDB), and Minimum Required Strength (MRS) Ratings for Thermoplastic Piping Materials or Pipe.
- E. Tubing shall be certified to NSF/ANSI 61 Drinking Water System Components-Health Effects, for use with Potable Water.
- F. Markings – Tubing shall be marked in accordance with ANSI/AWWA C904 Sec.6.1.
- G. Shipping and Delivery – Tubing shall be shipped and delivered in accordance with ANSI/AWWA C904 Sec 6.2.
- H. Affidavit of Compliance – The affidavit of compliance shall be in accordance with ANSI/AWWA C904 Sec 6.3 and shall be provided to the Owner prior to work.

COORDINATION

The Contractor shall be responsible for scheduling the work with the homeowner for water service replacement. The City of Muskegon will supply billing/contact information for each location.

PERMITS

Contractor shall be responsible for obtaining and paying for all permits and coordinating any inspections required including the City of Muskegon plumbing permit obtained from the building inspection department. A plumbing permit will be required for each location where a water service is replaced. The form to be filled out can be found at

<https://www.muskegon-mi.gov/cresources/Plumbing-Permit-Application.pdf>

CONSTRUCTION METHODS

- A. The water service from the property line, via meter pit, to a point that is 18 inches inside the wall or at the valve inside the wall, whichever comes first, shall be replaced. The water service from the property line, via curb stop, to the actual meter location inside the building, shall be replaced.
- B. Minimum depth of 5 ½ feet of bury below the existing grade.

City of Muskegon

- C. All water service pipe connections shall be inspected under pressure by Engineer prior to backfill.
- D. Backfill – Backfill materials shall meet the requirements of Section 902 of the 2012 Michigan Department of Transportation, “Standard Specifications for Construction.” All backfill to be compacted to 95% of maximum density.
- E. Tracer wire shall be installed for all PEX service lines.
- F. PEX tubing shall be placed with sufficient slack (snaking) to accommodate contraction prior to backfill.
- G. PEX tubing shall not be used in any location where there may be petroleum or chemical contamination in soil.
- H. When PEX is run through foundation or basement wall, it must be protected by a rigid sleeve that spans the distance from within the wall out to the undisturbed soil in the pipe trench. The purpose of this protective sleeve is to prevent shearing of the PEX tubing at the wall in the event of settlement in the backfill around the wall. At the point where the sleeve terminates inside the foundation or wall, the space between the PEX tubing and the sleeve should be sealed to prevent leakage into the building. **In no case should petroleum based caulk or sealant be used.**
- I. Final inspection – All inspections will be done by building inspections department, via plumbing permit. Contractor is to make all arrangements and coordination with inspections department.
- J. If any water service is found to serve as building electrical ground and a different method of grounding is needed, the ground shall be relocated to proper ground per all current State and local building codes. An electrical permit may be needed for this work. No additional cost will be awarded for this work. According to current code, a section of the existing water service line no less than 10 FT in length may be left in place and continue to serve as the electrical ground with no need for an electrical permit.

POST REPLACEMENT FLUSHING

The Contractor shall flush the service line immediately after all connections have been completed in accordance with the ANSI/AWWA C810-17: *Replacement and Flushing of Lead Service Lines*. Water shall be flushed from an outside connection such as a hose-bib or from hose on the house side of the meter. This shall be closest to the point of entry as possible. Flushing shall be done at full velocity for at least 10 minutes.

The Engineer shall provide the customer with instruction on interior flushing.

City of Muskegon

POST REPLACEMENT DOCUMENTATION - The Contractor shall document the replacement service on a form provided by the City of Muskegon. The documentation shall include measurements from curb stop to at least two permanent points such as building corners.

Before and after digital photographs of line replacement shall be provided to show pre-replacement conditions and post-replacement restoration.

The completion date and time shall be provided along with time of flushing.

WARRANTY - The contractor shall provide a written statement of warranty and protection for a period of one year from date of final acceptance. Warranty work shall cover cost to repair leaks and leak damage at no cost to the City of Muskegon.

SALVAGED MATERIALS - Any removed meters shall be become the property of the City of Muskegon and delivered to the City of Muskegon DPW, 1350 East Keating Avenue.

MEASUREMENT AND PAYMENT - The completed work for replacing the water service line to a point within the building, including all materials, labor, equipment and permits, as measured, will include the following pay items at the contract price. Pay item of "WATER SERVICE, PRIVATE PROPERTY" shall include all material, labor, equipment, flushing, disinfection and installation of service line from curb stop/meter pit to exterior of foundation wall. Pay item of "WATER SERVICE, BUILDING CONNECTION" shall include everything beyond the exterior of the foundation wall, including all materials, labor, permits, coordination, scheduling and any possible electrical grounding modifications, to get the new service threw the foundation all and make the connection to existing plumbing.

PAY ITEM

PAY UNIT

Water Service, Private Property, __ inch

LFT

Water Service, Building Connection, __ inch

EACH

**CITY OF MUSKEGON
SPECIAL PROVISIONS
FOR
METER PIT COMPLETE**

1 OF 1

February 2022

City of Muskegon

DESCRIPTION

The work covered by this special provision shall consist of constructing water meter pits according to the detail for Meter Pit Complete on the Construction Plans.

MATERIALS

The materials will conform to those shown on the detail for Meter Pit Complete on the Construction Plans. The meter will be provided and installed by the City of Muskegon.

CONSTRUCTION METHODS

The work covered by this special provision shall be in accordance with the detail for Meter Pit Complete on the Construction Plans.

MEASUREMENT AND PAYMENT

The completed work including all materials, labor and equipment, will be measured and paid for at the contract unit price for the following contract item (pay item).

Pay Item

Pay Unit:

Meter Pit Complete

Each

**CITY OF MUSKEGON
SPECIAL PROVISION
FOR
VALVE, __ INCH, GATE, WITH BOX**

1 of 1

May 2022

City of Muskegon

DESCRIPTION:

This special provision defines and describes the methods and materials required to place new gate valves.

MATERIALS:

Gate Valves: Valves shall be iron body, bronze mounted, double disc, parallel seat, with a 2" operating nut open to the right with the direction indicated by an arrow cast on the valve. End connections shall be mechanical joint for all valves. Valves shall have a bronze stem, o-ring stem seal, non-rising stem, and shall have a clean waterway equivalent in area, when open, equal to that of the connecting pipe. All valves shall be of new construction and be complete with all operating equipment and other appurtenances necessary for operation. Valves shall be designed to maintain a minimum 250 pound working pressure, tested at 300 pounds for sizes 14" through 48" or minimum 200 pound working pressure and tested at 400 pounds for sizes 2" through 12" and manufactured as per AWWA C500. All mechanical joints shall be restrained with retaining glands. Resilient Wedge Valves will be allowed on this project. Valves shall have a continuity strip placed from retainer gland to retainer gland in order to pass electrical conductivity on watermain & appurtenances. The boxes and covers shall be East Jordan no. 6860 with base no. 6 or approved by engineer.

CONSTRUCTION

The work shall include all necessary materials, equipment and labor to excavate, place, and connect the new valve. The valve stem shall be plum and the valve box shall be centered on the valve nut. The valve box shall be flush with the finish terrace grade or adjusted to finish pavement grade as shown on the detail for Water Valve Box and Cover, Complete on the construction plans and will not be paid for separately.

MEASUREMENT AND PAYMENT:

The completed work including all materials, labor and equipment, will be measured and paid for at the contract unit price for the following contract item (pay item).

PAY ITEM

PAY UNIT

Valve, _ inch, Gate, With Box Each

Water Valve Box and Cover, Complete Each

MICHIGAN
DEPARTMENT OF TRANSPORTATION

SPECIAL PROVISION
FOR
AUTOMATED MACHINE GUIDANCE

DES:DJB

1 of 3

APPR:DMG:MRB:04-29-20
FHWA:APPR:05-06-20

a. Description. The Contractor may elect to utilize automated machine guidance (AMG) to determine three-dimensional locations for earth work activities and material placement. AMG is the process of automatically adjusting the motion of a machine with an onboard computer that obtains its position from global positioning systems, robotic total stations, lasers, or combinations of similar methods while referencing the Contractor's model developed for the project. This procedure can be used in operations such as earth excavation, material placement, grading, trimming, and/or paving.

b. Materials. None specified.

c. Construction.

1. AMG Intent. The Contractor will notify the Engineer of the intent to use AMG within 10 calendar days of Award.

2. AMG Work Plan. If AMG will be used, provide an AMG work plan to the Engineer at least 2 weeks prior to the start of AMG operations. The use of AMG may require conventional staking if the intent to use AMG is submitted after operations have commenced.

Each Contractor using AMG will provide an AMG work plan to indicate the items of work covered within subsections 824.03.C and/or 824.03.D of the Standard Specifications for Construction, type of AMG procedure, anticipated accuracy of each operation, and any areas where AMG operations need to be supplemented with conventional staking. The AMG work plan must identify the Contractor's past experience with AMG operations, model revision procedure(s), description of AMG equipment, equipment calibration procedures, equipment calibration frequency, and a description of the control necessary to support the proposed AMG operation(s). The AMG work plan must designate a primary AMG contact. The Engineer reserves the right to request additional information or clarification prior to the approval of the AMG work plan.

3. Survey Meeting. At the discretion of the Engineer, a meeting with the Contractor and other involved parties (e.g. MDOT personnel, designer of record/representative, AMG contact, Contractor's model creator, surveyors, inspectors, etc.) may be held prior to field operations. The purpose of the meeting is to discuss the implementation of the AMG work plan and exchange of electronic data between both parties. The Contractor must explain the operations and procedures for the AMG technology, discuss the development of the Contractor's model, and present their survey control plan. The meeting attendees may also discuss the workflow for field verification, steps to be taken to resolve concerns with the Contractor's model, and compliance of AMG operations with the contract.

4. Contractor Model.

A. Transmit, to the Department a certification statement which states in part the following: "The Contractor's model(s) developed for the project is(are) an accurate representation of the contract, submittal of this certification is in accordance with the Contractor's obligations and requirements within the Contractor Staking Quality Control Plan and approved AMG work plan.

B. The Contract and Reference Information Documents (RID). Create the model based upon the contract. RID reference documents for the project may be used for creation of the model at the Contractor's discretion. Bring any conflicts identified between the contract and RID documents to the attention of the Engineer. If the Contractor determines a need for additional data or requires electronic formatting of files different than provided, it is the responsibility of the Contractor to prepare such files prior to commencement of the AMG operation without additional costs to the Department.

C. Liability and Verification. The contract will govern construction activities. The Department will not approve the Contractor's model(s). The Contractor accepts all liability associated with the creation and use of the Contractor's model. Field verify existing project features to determine the suitability of any provided contract information. Features to be verified include, but are not limited to, ties at project limits, bridges, ramps, control points, benchmarks, section corners, monuments, and other critical locations.

D. Sharing and Maintenance. Provide the model or phased model as outlined in the approved AMG work plan to the Engineer at least 10 calendar days prior to the start of any AMG operations: Submit 3D Line String Models in Drawing Exchange Format (DXF) and Triangle Models in an Extensible Markup Language (XML) using file naming consistent with the [Contractor Standard Naming Conventions for Document Submittals](#). If changes are made to the model(s) during the course of construction, submit the revised model(s) to the Engineer in accordance with the model revision procedure(s) outlined in the approved AMG work plan.

5. Control.

A. Contractor Staking. The Engineer will provide horizontal and vertical control points, in accordance with subsection 104.09.A of the Standard Specifications for Construction, to be verified by the Contractor prior to the commencement of any AMG operations. Notify the Engineer if any control points exceed the tolerances established in section 824 of the Standard Specifications for Construction.

If the Contractor's AMG operation requires a greater density of control than that provided from the Engineer, the Contractor is responsible for densification of the AMG control. Establish the additional AMG control with sufficient frequency and precision to adequately support the AMG operation being performed. Ensure the control points are stable and properly marked to allow verification activities to be performed by the Engineer. Submit initial AMG control information (Point, Northing, Easting, Elevation, and Description) to the Engineer at least 2 calendar days prior to AMG operations. Ensure any subsequent AMG control information is provided in the same format and time consideration.

The Contractor must provide and maintain one set of stakes denoting control points (subsection 824.03.A of the Standard Specifications for Construction) and every 200 feet

with the station and offset clearly labeled for each roadway alignment.

B. Engineer Staking. If section 824 of the Standard Specifications for Construction is not part of the contract and the Contractor's AMG operation requires a greater density of AMG control, the Engineer will provide AMG control that will be established with sufficient frequency and precision to adequately support the AMG operation being performed. Request AMG control from the Engineer at least 10 calendar days prior to the commencement of AMG operations. The Engineer will provide the AMG control information to the Contractor at least 2 calendar days prior to AMG operations.

6. Contractor Responsibility. The Contractor's AMG operation can only eliminate staking required for items as described in the approved AMG work plan. The Contractor is responsible for all quality control necessary for their AMG operations to meet the prescribed tolerances for each associated pay item. If prescribed tolerances are not met, the Contractor will either proceed with regular operations without the use of AMG or suspend operations to evaluate and address the AMG operations deficiencies. Once the cause of the inaccuracies is determined, the Contractor must provide the Engineer with a written corrective action plan addressing the concerns for the Engineer's approval. The Contractor may only resume AMG operations with the approval of the Engineer. If subsequent failures to meet specifications and accuracies are experienced, the Contractor will be suspended from AMG operations and conventional staking/operations must be provided at no additional cost to the Department.

Notify the Engineer at least 24 hours prior to commencement of AMG operations.

7. Quality Assurance. The Engineer will perform continuous and independent quality assurance for AMG operations to ensure compliance of the finished surfaces in accordance with the contract. The Engineer will use equipment and methods that adequately support the precision level of the verification. The Engineer is prohibited from using the Contractor's equipment in the quality assurance verification process. Acceptance of the results of AMG operations will be based upon quality assurance results falling within prescribed tolerances for each associated pay item. If the Engineer determines that the prescribed tolerances are not being met, the Contractor must suspend AMG operations.

d. Measurement and Payment. When the Engineer directs a change to the contract that requires a revision to the Contractor's model a work order will be generated that includes the number of hours agreed upon between the Engineer and the Contractor. Hours not documented on the work order will not be paid for by the Engineer unless approved otherwise.

The Department will pay for electronic model revisions using the following pay item:

Pay Item	Pay Unit
Electronic Model Revision	Hour

Electronic Model Revision includes compensation for revisions to the Contractor's model. **Electronic Model Revision** will be paid for at a fixed unit price of \$150.00 per hour.

**CITY OF MUSKEGON
SPECIAL PROVISION
FOR
IRRIGATION REPAIR**

1 of 2

September 2022

City of Muskegon

DESCRIPTION

Restore existing privately-owned underground sprinkling systems within the project site as described herein. This work shall be paid with an allowance for the actual work required to restore and modify existing privately-owned underground sprinkling systems. The Contractor shall take care to avoid disturbance of existing underground sprinkling systems within the project site. These typically will be encountered in the parkway adjacent to the roadway.

MATERIALS

Materials used to restore or modify existing underground sprinkling systems shall be of the same brand, model and specifications as the removed or damaged portion(s) of the sprinkling system and shall be compatible with the rest of the system.

CONSTRUCTION

The Contractor shall take precautions to prevent or minimize damage and disruption to private lawn sprinkling systems, including, but not limited to, completing visual inspections of the project site to determine areas in which lawn sprinkling equipment exists. This work of inspection shall be considered incidental to the disturbing work in the project area.

The Contractor shall repair or replace all lawn sprinkling systems disturbed by his/her operations and shall contact and coordinate any necessary work with the appropriate owners of such sprinkling systems. The Contractor shall obtain written permission from property owners prior to completing any work outside the R.O.W. on private property, and shall provide copies of these documents to the Engineer for the project file.

The Contractor shall employ an underground sprinkling specialist to make necessary repairs or modifications to the affected underground sprinkling systems. During construction activities, the disturbed portions of the system shall be isolated and/or removed in such a way that the undisturbed portions of the system remain operational until the entire system is completely restored. The existing underground sprinkling systems shall be restored or modified so that spray from the sprinkler heads does not spray over sidewalks or into driving lanes of the road.

IRRIGATION REPAIR

2 of 2

MEASUREMENT AND PAYMENT

The completed work including all material, labor and equipment will be measured and paid for at the contract unit price for the following contract item(s) (pay item).

PAY ITEM

PAY UNIT

Irrigation Repair

Dollar

Payment for **Irrigation Repair** will be paid for as an allowance after all disturbed sprinkling systems have been repaired and/or replaced, whichever occurs later. The Contractor shall supply the Engineer with actual invoices from the underground sprinkling specialist for this work effort and may add up to 5% markup.

The Contractor waives all claim for damages or delay which he/she may suffer by reason of the presence of lawn sprinkling equipment within the project site, and understands that no extra compensation will be paid to him/her due to any lawn sprinkling equipment encountered.

PART 6 – MDOT SPECIFICATIONS

* MAXIMUM LANDING SLOPE IS 2.0% IN EACH DIRECTION OF TRAVEL. LANDING MINIMUM DIMENSIONS 5' x 5'. SEE NOTES. IF THE RAMP RUNNING SLOPE IS LESS THAN 5% A TOP LANDING IS NOT REQUIRED.

** MAXIMUM RAMP CROSS SLOPE IS 2.0%, RUNNING SLOPE 5% - 7% (8.3% MAXIMUM). SEE NOTES.

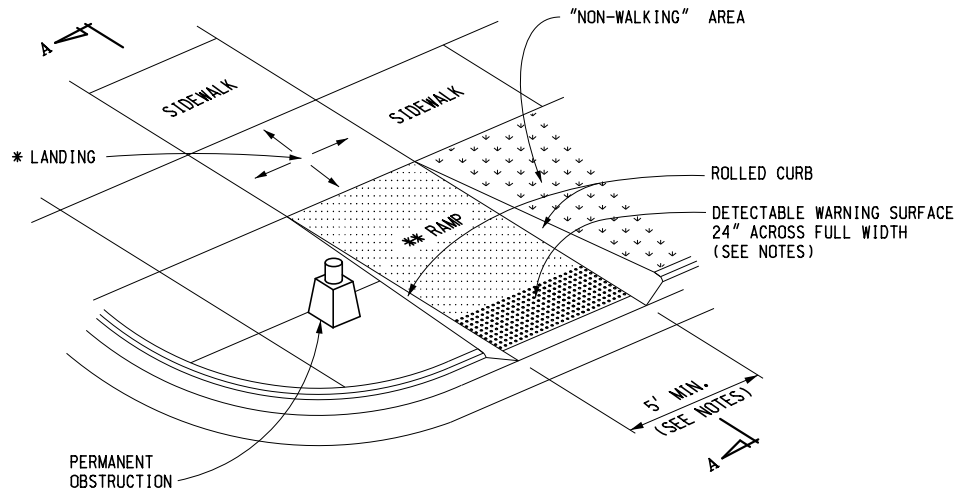

SIDEWALK RAMP TYPE R
(ROLLED SIDES)

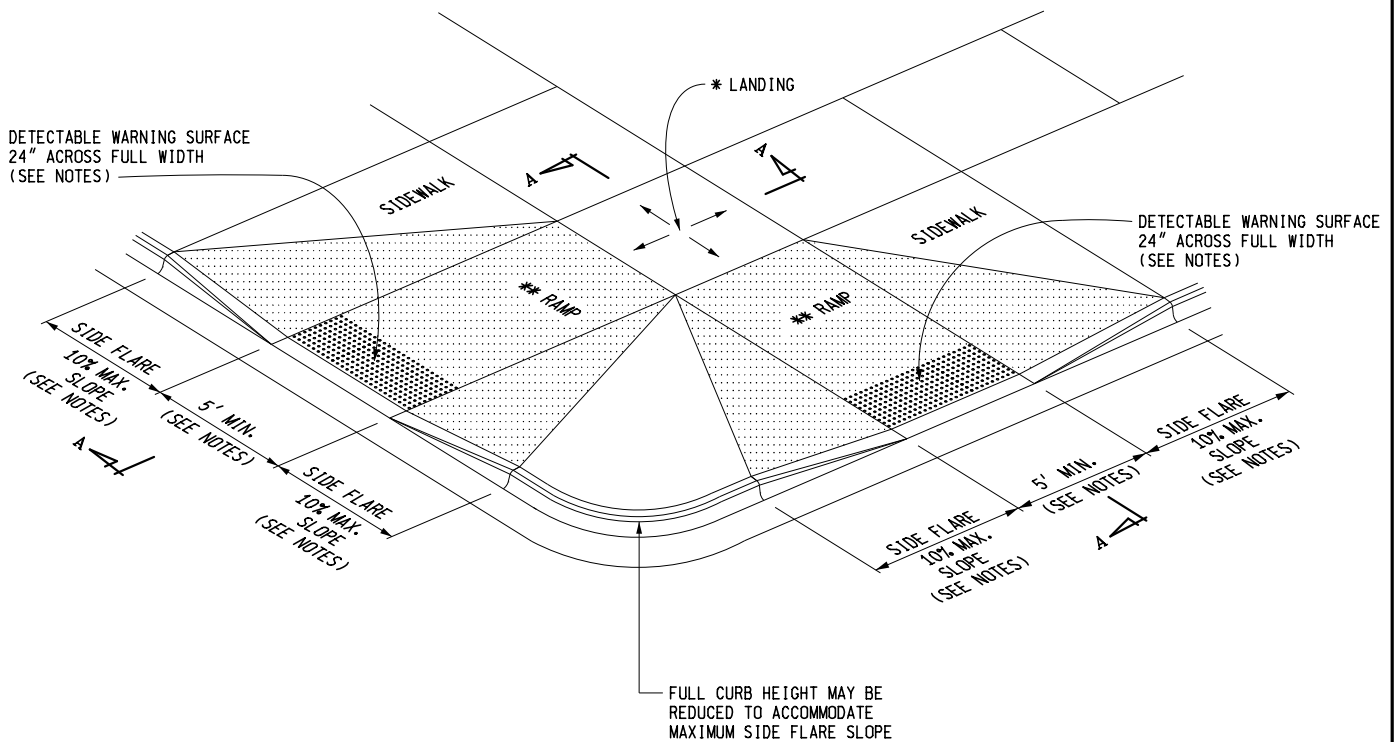

SIDEWALK RAMP TYPE F
(FLARED SIDES, TWO RAMPS SHOWN)



PREPARED BY
DESIGN DIVISION

DRAWN BY: B.L.T.

CHECKED BY: W.K.P.

DEPARTMENT DIRECTOR
Kirk T. Steudle

APPROVED BY: _____
DIRECTOR, BUREAU OF FIELD SERVICES

APPROVED BY: _____
DIRECTOR, BUREAU OF DEVELOPMENT

MICHIGAN DEPARTMENT OF TRANSPORTATION
BUREAU OF DEVELOPMENT STANDARD PLAN FOR

**SIDEWALK RAMP AND
DETECTABLE WARNING DETAILS**

F.H.W.A. APPROVAL

10-20-2017
PLAN DATE

R-28-J

SHEET
1 OF 7

* MAXIMUM LANDING SLOPE IS 2.0% IN EACH DIRECTION OF TRAVEL. LANDING MINIMUM DIMENSIONS 5' x 5'. SEE NOTES. IF THE RAMP RUNNING SLOPE IS LESS THAN 5% A TOP LANDING IS NOT REQUIRED.

** MAXIMUM RAMP CROSS SLOPE IS 2.0%, RUNNING SLOPE 5% - 7% (8.3% MAXIMUM). SEE NOTES.

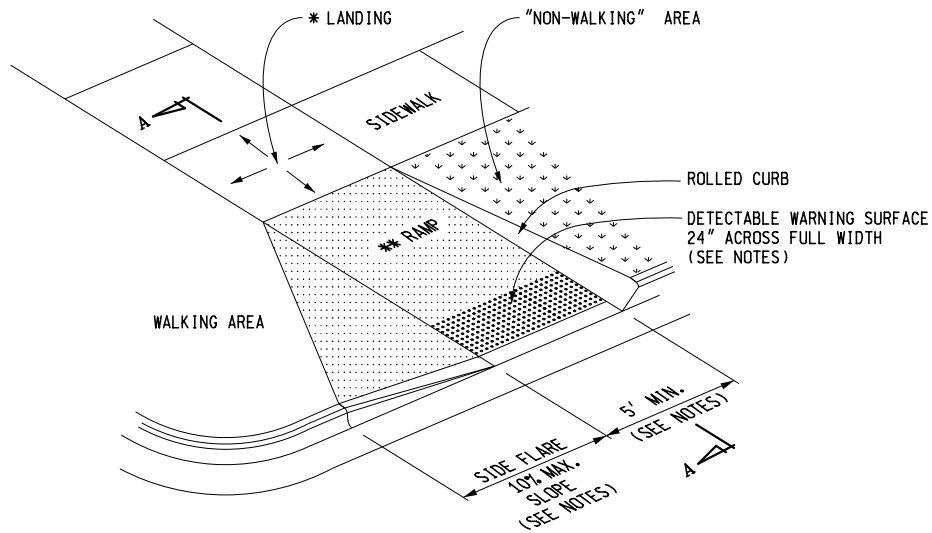

SIDEWALK RAMP TYPE RF
(ROLLED / FLARED SIDES)

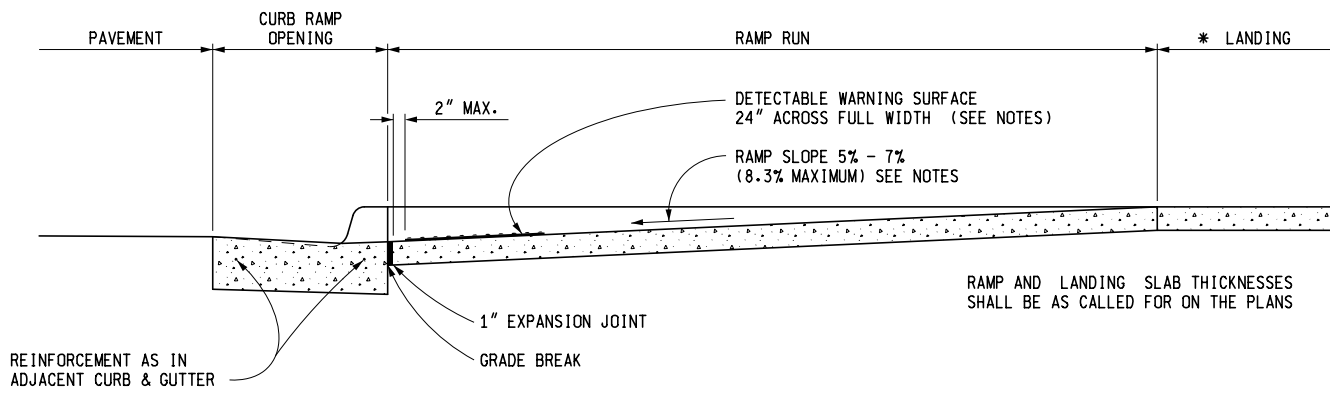

RAMP AND LANDING SLAB THICKNESSES SHALL BE AS CALLED FOR ON THE PLANS

REINFORCEMENT AS IN ADJACENT CURB & GUTTER

CURB TYPE	MAXIMUM RISE (INCHES)	
	A	B
B1	3/4	1
B2	3/4	1
B3	3/4	1
D1	3/4	1
D2	3/4	1
D3	3/4	1
C1	1/2	1/2
C2	1/2	1/2
C3	3/4	1/2
C4	3/4	1/2
C5	1	1/2
C6	1	1/2
F1	1/2	1/2
F2	1/2	1/2
F3	3/4	1/2
F4	3/4	1/2
F5	1	1/2
F6	1	1/2

FOR CURB TYPES SEE STANDARD PLAN R-30-SERIES

SECTION A-A

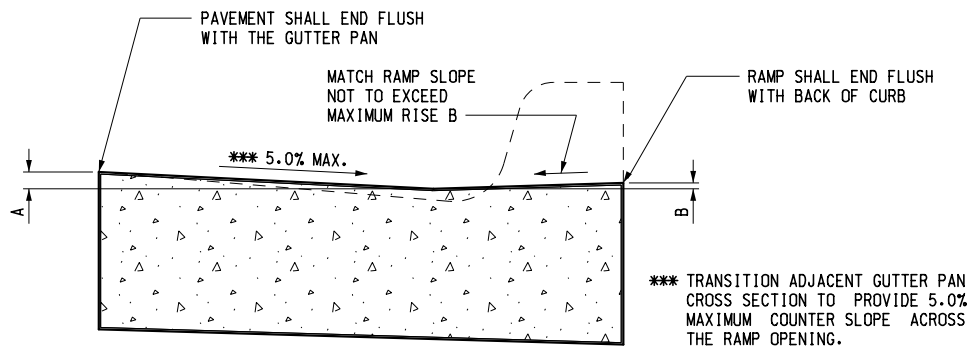

SECTION THROUGH CURB RAMP OPENING
(TYPICAL ALL RAMP TYPES)

MICHIGAN DEPARTMENT OF TRANSPORTATION
BUREAU OF DEVELOPMENT STANDARD PLAN FOR
**SIDEWALK RAMP AND
DETECTABLE WARNING DETAILS**

* MAXIMUM LANDING SLOPE IS 2.0% IN EACH DIRECTION OF TRAVEL. LANDING MINIMUM DIMENSIONS 5' x 5'. SEE NOTES. IF THE RAMP RUNNING SLOPE IS LESS THAN 5% A TOP LANDING IS NOT REQUIRED.

** MAXIMUM RAMP CROSS SLOPE IS 2.0%, RUNNING SLOPE 5% - 7% (8.3% MAXIMUM). SEE NOTES.

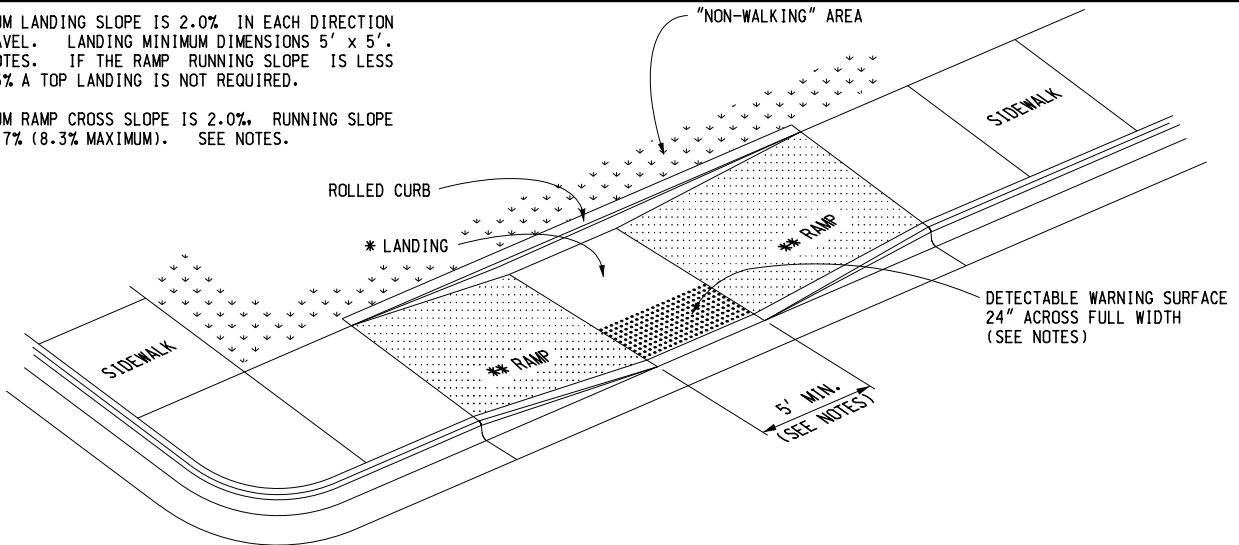

SIDEWALK RAMP TYPE P

(PARALLEL RAMP)

DO NOT USE IN AREAS WHERE PONDING MAY OCCUR

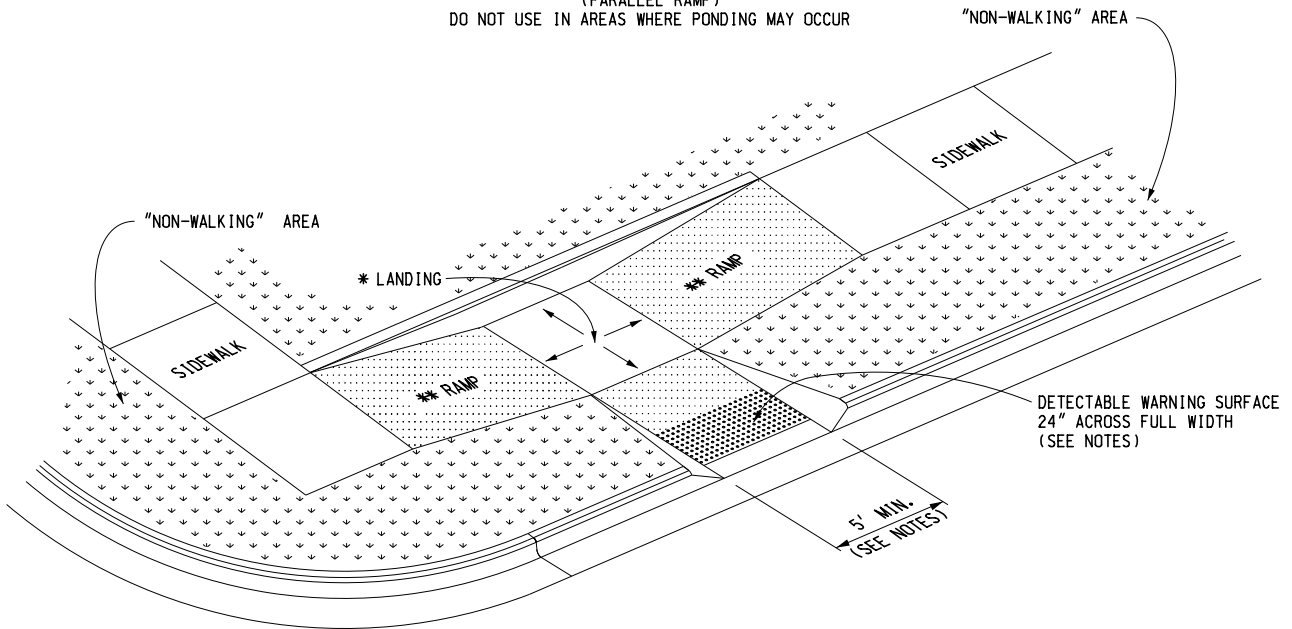

SIDEWALK RAMP TYPE C

(COMBINATION RAMP)

DETECTABLE WARNING SURFACE 24" ACROSS FULL WIDTH IF MEDIAN WIDTH IS AT LEAST 6'-0". OTHERWISE NO DETECTABLE WARNING IS REQUIRED.

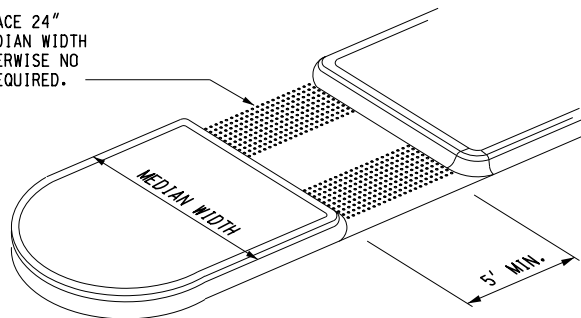

SIDEWALK RAMP TYPE M

(MEDIAN ISLAND)

MICHIGAN DEPARTMENT OF TRANSPORTATION
BUREAU OF DEVELOPMENT STANDARD PLAN FOR

**SIDEWALK RAMP AND
DETECTABLE WARNING DETAILS**

F.H.W.A. APPROVAL	10-20-2017 PLAN DATE	R-28-J	SHEET 3 OF 7
-------------------	-------------------------	--------	-----------------

* MAXIMUM LANDING SLOPE IS 2.0% IN EACH DIRECTION OF TRAVEL. LANDING MINIMUM DIMENSIONS 5' x 5'. SEE NOTES. IF THE RAMP RUNNING SLOPE IS LESS THAN 5% A TOP LANDING IS NOT REQUIRED.

** MAXIMUM RAMP CROSS SLOPE IS 2.0%, RUNNING SLOPE 5% - 7% (8.3% MAXIMUM). SEE NOTES.

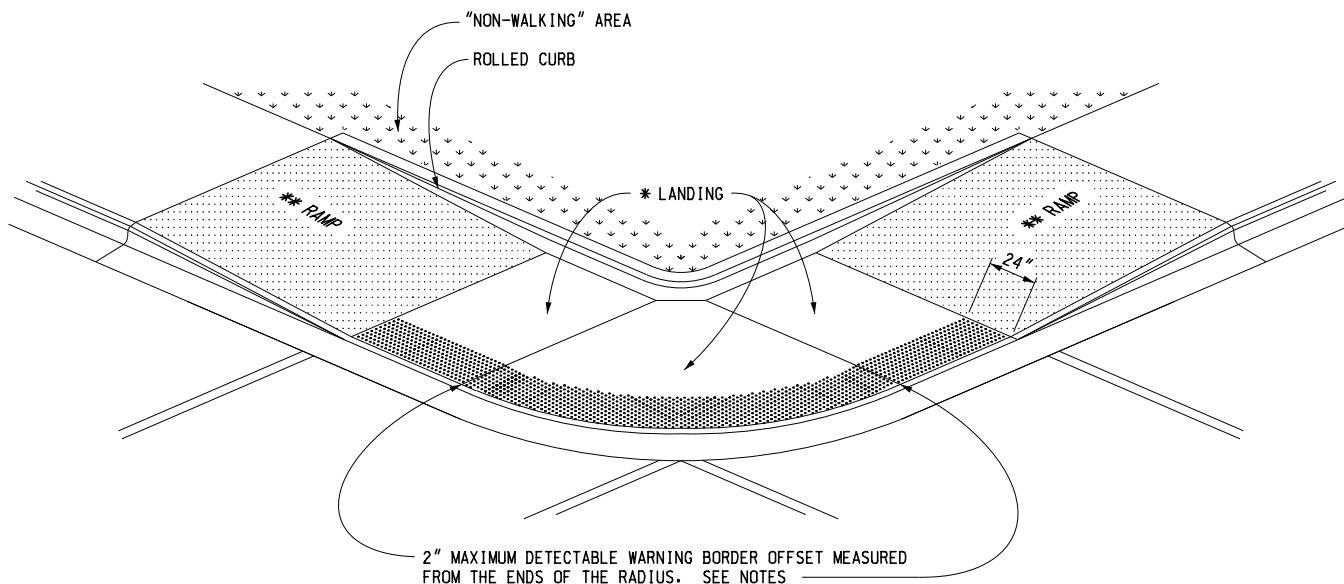

(RADIAL DETECTABLE WARNING SHOWN)

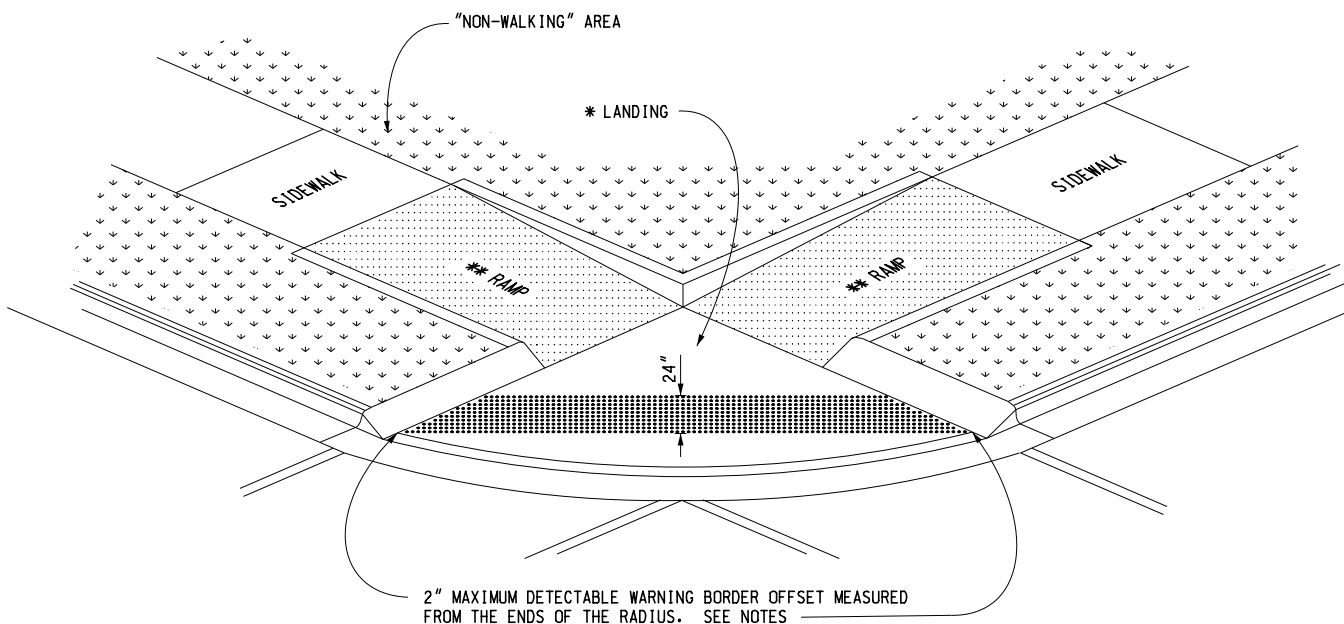

(TANGENT DETECTABLE WARNING SHOWN)

SIDEWALK RAMP TYPE D

(DEPRESSED CORNER)

USE ONLY WHEN INDEPENDENT DIRECTIONAL RAMPS CAN NOT BE CONSTRUCTED FOR EACH CROSSING DIRECTION

MICHIGAN DEPARTMENT OF TRANSPORTATION
 BUREAU OF DEVELOPMENT STANDARD PLAN FOR

**SIDEWALK RAMP AND
 DETECTABLE WARNING DETAILS**

F.H.W.A. APPROVAL

10-20-2017
 PLAN DATE

R-28-J

SHEET
 4 OF 7

* THE DETECTABLE WARNING SURFACE SHALL BE LOCATED SO THAT THE EDGE NEAREST THE RAIL CROSSING IS 6' MINIMUM AND 15' MAXIMUM FROM THE CENTERLINE OF THE NEAREST RAIL. DO NOT PLACE DETECTABLE WARNING ON RAILROAD CROSSING MATERIAL.

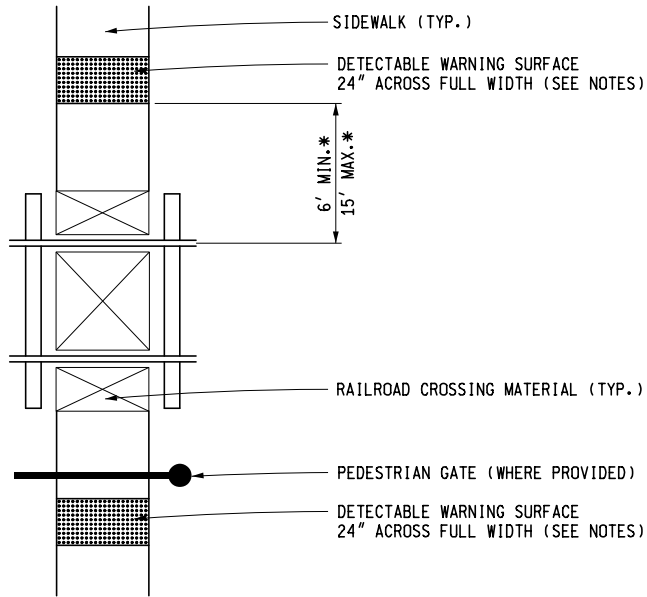

DETECTABLE WARNING AT RAILROAD CROSSING

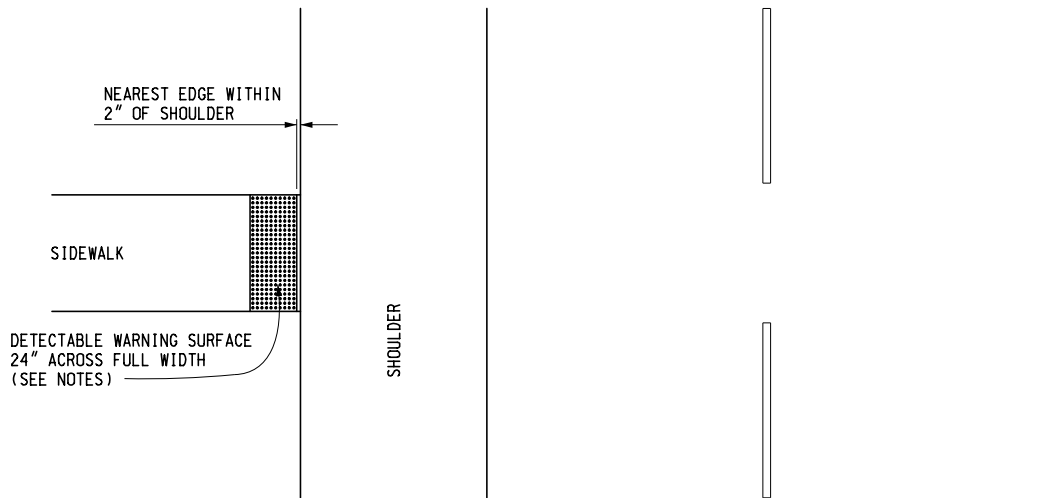

DETECTABLE WARNING AT FLUSH SHOULDER OR ROADWAY

MICHIGAN DEPARTMENT OF TRANSPORTATION BUREAU OF DEVELOPMENT STANDARD PLAN FOR		
SIDEWALK RAMP AND DETECTABLE WARNING DETAILS		
F.H.W.A. APPROVAL	10-20-2017 PLAN DATE	R-28-J
		SHEET 5 OF 7

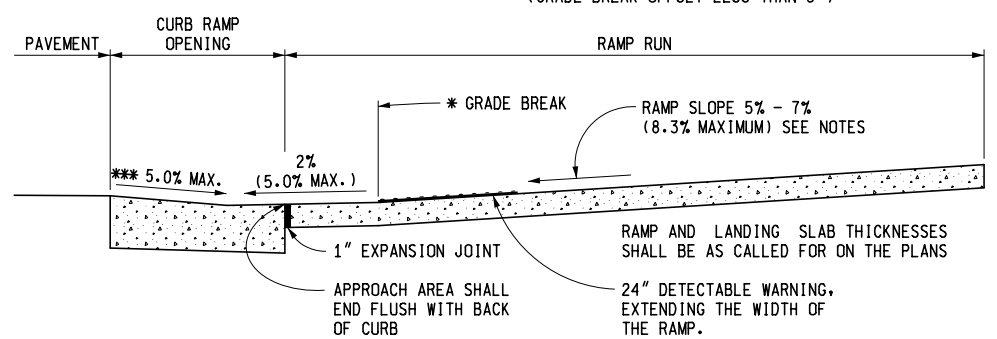
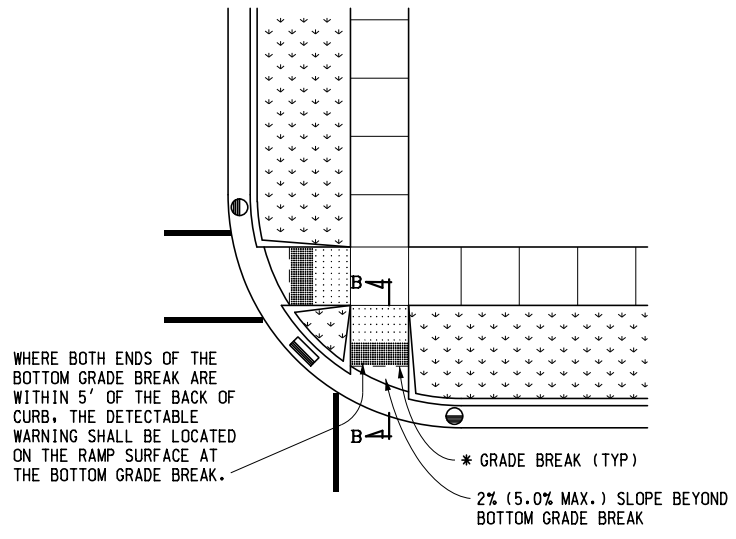
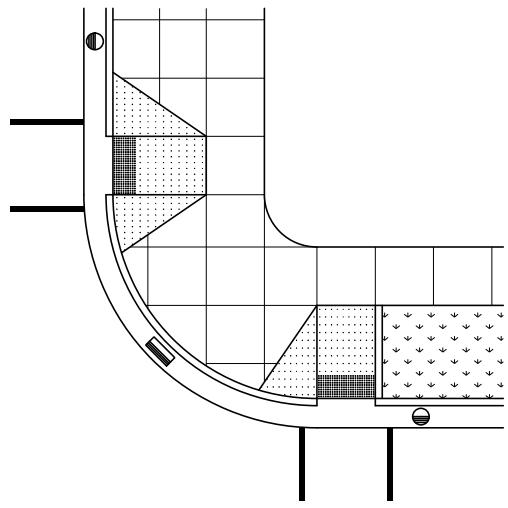
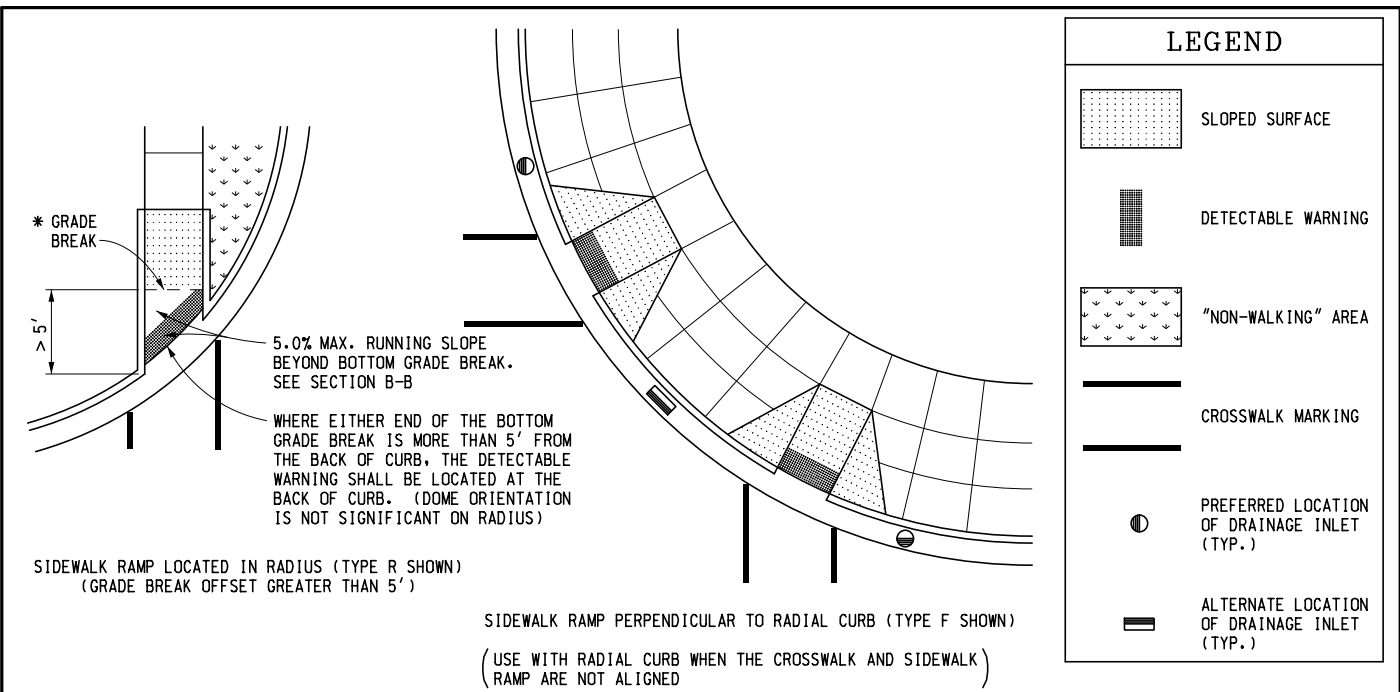

* GRADE BREAKS AT THE TOP AND BOTTOM OF CURB RAMPS SHALL BE PERPENDICULAR TO THE DIRECTION OF TRAVEL.

*** TRANSITION ADJACENT GUTTER PAN CROSS SECTION TO PROVIDE 5.0% MAXIMUM COUNTER SLOPE ACROSS THE RAMP OPENING.

SEE SHEET 2 FOR CURB RAMP OPENING DETAILS.

SECTION B-B
SIDEWALK RAMP ORIENTATION

MICHIGAN DEPARTMENT OF TRANSPORTATION
BUREAU OF DEVELOPMENT STANDARD PLAN FOR

**SIDEWALK RAMP AND
DETECTABLE WARNING DETAILS**

F.H.W.A. APPROVAL	10-20-2017 PLAN DATE	R-28-J	SHEET 6 OF 7
-------------------	-------------------------	--------	-----------------

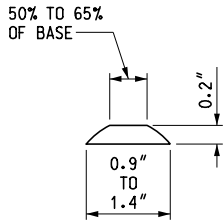

DOMES SECTION

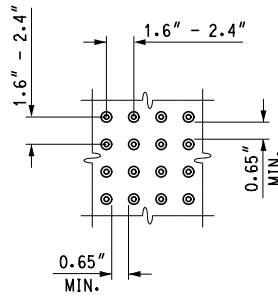

DOMES SPACING

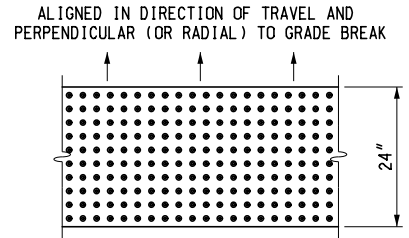

DOMES ALIGNMENT

DETECTABLE WARNING DETAILS

NOTES:

DETAILS SPECIFIED ON THIS PLAN APPLY TO ALL CONSTRUCTION, RECONSTRUCTION, OR ALTERATION OF STREETS, CURBS, OR SIDEWALKS IN THE PUBLIC RIGHT OF WAY.

SIDEWALK RAMPS ARE TO BE LOCATED AS SPECIFIED ON THE PLANS OR AS DIRECTED BY THE ENGINEER.

RAMPS SHALL BE PROVIDED AT ALL CORNERS OF AN INTERSECTION WHERE THERE IS EXISTING OR PROPOSED SIDEWALK AND CURB. RAMPS SHALL ALSO BE PROVIDED AT MARKED AND/OR SIGNALIZED MID-BLOCK CROSSINGS.

SURFACE TEXTURE OF THE RAMP SHALL BE THAT OBTAINED BY A COARSE BROOMING, TRANSVERSE TO THE RUNNING SLOPE.

SIDEWALK SHALL BE RAMPED WHERE THE DRIVEWAY CURB IS EXTENDED ACROSS THE WALK.

CARE SHALL BE TAKEN TO ASSURE A UNIFORM GRADE ON THE RAMP. WHERE CONDITIONS PERMIT, IT IS DESIRABLE THAT THE SLOPE OF THE RAMP BE IN ONLY ONE DIRECTION, PARALLEL TO THE DIRECTION OF TRAVEL.

RAMP WIDTH SHALL BE INCREASED, IF NECESSARY, TO ACCOMMODATE SIDEWALK SNOW REMOVAL EQUIPMENT NORMALLY USED BY THE MUNICIPALITY.

WHEN 5' MINIMUM WIDTHS ARE NOT PRACTICABLE, RAMP WIDTH MAY BE REDUCED TO NOT LESS THAN 4' AND LANDINGS TO NOT LESS THAN 4' x 4'.

DETECTABLE WARNING SURFACE COVERAGE IS 24" MINIMUM IN THE DIRECTION OF RAMP/PATH TRAVEL AND THE FULL WIDTH OF THE RAMP/PATH OPENING EXCLUDING CURBED OR FLARED CURB TRANSITION AREAS. A BORDER OFFSET NOT GREATER THAN 2" MEASURED ALONG THE EDGES OF THE DETECTABLE WARNING IS ALLOWABLE. FOR RADIAL CURB THE OFFSET IS MEASURED FROM THE ENDS OF THE RADIUS.

FOR NEW ROADWAY CONSTRUCTION, THE RAMP CROSS SLOPE MAY NOT EXCEED 2.0%. FOR ALTERATIONS TO EXISTING ROADWAYS, THE CROSS SLOPE MAY BE TRANSITIONED TO MEET AN EXISTING ROADWAY GRADE. THE CROSS SLOPE TRANSITION SHALL BE APPLIED UNIFORMLY OVER THE FULL LENGTH OF THE RAMP.

THE MAXIMUM RUNNING SLOPE OF 8.3% IS RELATIVE TO A FLAT (0%) REFERENCE. HOWEVER, IT SHALL NOT REQUIRE ANY RAMP OR SERIES OF RAMPS TO EXCEED 15 FEET IN LENGTH NOT INCLUDING LANDINGS OR TRANSITIONS.

DRAINAGE STRUCTURES SHOULD NOT BE PLACED IN LINE WITH RAMPS. THE LOCATION OF THE RAMP SHOULD TAKE PRECEDENCE OVER THE LOCATION OF THE DRAINAGE STRUCTURE. WHERE EXISTING DRAINAGE STRUCTURES ARE LOCATED IN THE RAMP PATH OF TRAVEL, USE A MANUFACTURER'S ADA COMPLIANT GRATE. OPENINGS SHALL NOT BE GREATER THAN 1/2". ELONGATED OPENINGS SHALL BE PLACED SO THAT THE LONG DIMENSION IS PERPENDICULAR TO THE DOMINANT DIRECTION OF TRAVEL.

THE TOP OF THE JOINT FILLER FOR ALL RAMP TYPES SHALL BE FLUSH WITH THE ADJACENT CONCRETE.

CROSSWALK AND STOP LINE MARKINGS, IF USED, SHALL BE SO LOCATED AS TO STOP TRAFFIC SHORT OF RAMP CROSSINGS. SPECIFIC DETAILS FOR MARKING APPLICATIONS ARE GIVEN IN THE "MICHIGAN MANUAL ON UNIFORM TRAFFIC CONTROL DEVICES".

FLARED SIDES WITH A SLOPE OF 10% MAXIMUM, MEASURED ALONG THE ROADSIDE CURB LINE, SHALL BE PROVIDED WHERE AN UNOBSTRUCTED CIRCULATION PATH LATERALLY CROSSES THE SIDEWALK RAMP. FLARED SIDES ARE NOT REQUIRED WHERE THE RAMP IS BORDERED BY LANDSCAPING, UNPAVED SURFACE OR PERMANENT FIXED OBJECTS. WHERE THEY ARE NOT REQUIRED, FLARED SIDES CAN BE CONSIDERED IN ORDER TO AVOID SHARP CURB RETURNS AT RAMP OPENINGS.

DETECTABLE WARNING PLATES MUST BE INSTALLED USING FABRICATED OR FIELD CUT UNITS CAST AND/OR ANCHORED IN THE PAVEMENT TO RESIST SHIFTING OR HEAVING.

MICHIGAN DEPARTMENT OF TRANSPORTATION
BUREAU OF DEVELOPMENT STANDARD PLAN FOR

**SIDEWALK RAMP AND
DETECTABLE WARNING DETAILS**

F.H.W.A. APPROVAL	10-20-2017 PLAN DATE	R-28-J	SHEET 7 OF 7
-------------------	-------------------------	--------	-----------------

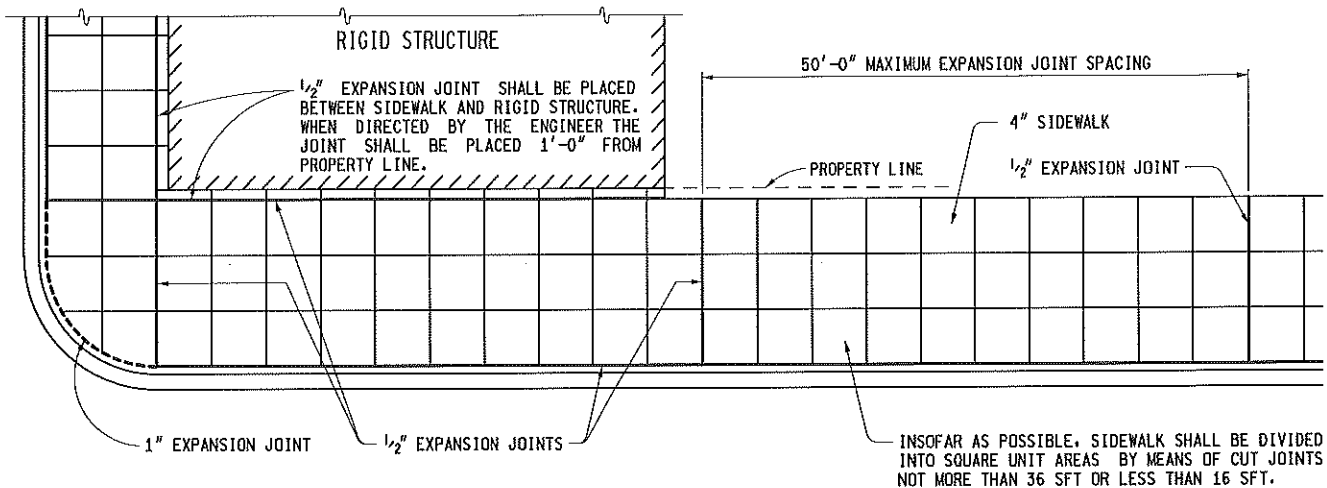
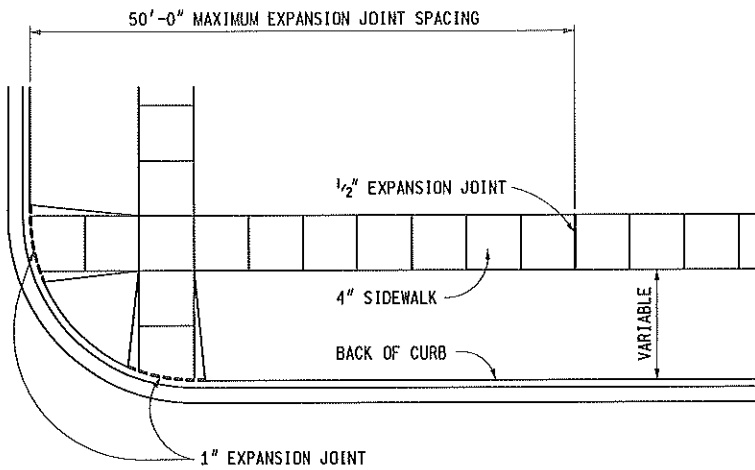

LOCATION OF JOINTS IN CONCRETE SIDEWALK

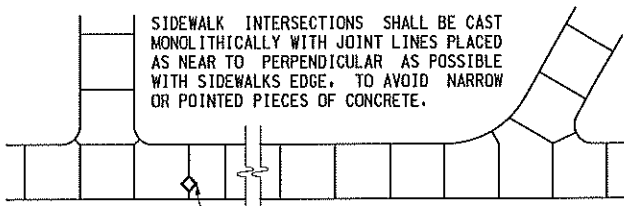

WHERE A PERMANENT STRUCTURE IS LOCATED IN SIDEWALK, PLACE EXPANSION MATERIAL AROUND STRUCTURE AND ADJUST JOINT PATTERN TO INTERSECT STRUCTURE AS ILLUSTRATED.

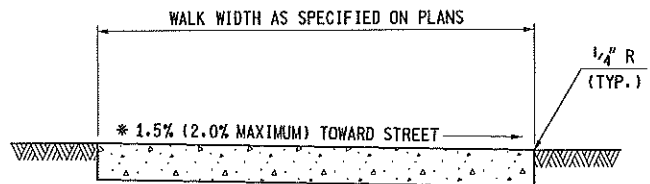

* SEE NOTES

TYPICAL SIDEWALK JOINT LAYOUTS

4" CONCRETE SIDEWALK



PREPARED BY
DESIGN DIVISION
DRAWN BY: B.L.T.
CHECKED BY: W.K.P.

DEPARTMENT DIRECTOR
Kirk T. Steudle

APPROVED BY: Randy Van Pelt
DIRECTOR, BUREAU OF FIELD SERVICES

APPROVED BY: Maia A. Van Pelt
DIRECTOR, BUREAU OF HIGHWAY DEVELOPMENT

MICHIGAN DEPARTMENT OF TRANSPORTATION
BUREAU OF HIGHWAY DEVELOPMENT STANDARD PLAN FOR

**DRIVEWAY OPENINGS
& APPROACHES,
AND CONCRETE SIDEWALK**

9-30-2014
F.H.W.A. APPROVAL

7-1-2014
PLAN DATE

R-29-I

SHEET
1 OF 4

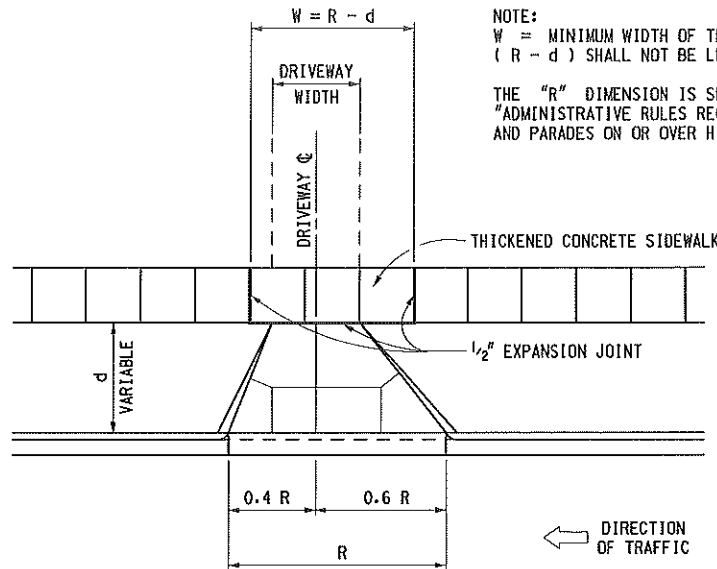

NOTE:
 W = MINIMUM WIDTH OF THICKENED CONCRETE SIDEWALK.
 $(R - d)$ SHALL NOT BE LESS THAN DRIVEWAY WIDTH.

THE "R" DIMENSION IS SPECIFIED IN THE PUBLICATION
 "ADMINISTRATIVE RULES REGULATING DRIVEWAYS, BANNERS
 AND PARADES ON OR OVER HIGHWAYS".

CONCRETE DRIVEWAY OPENING LAYOUT

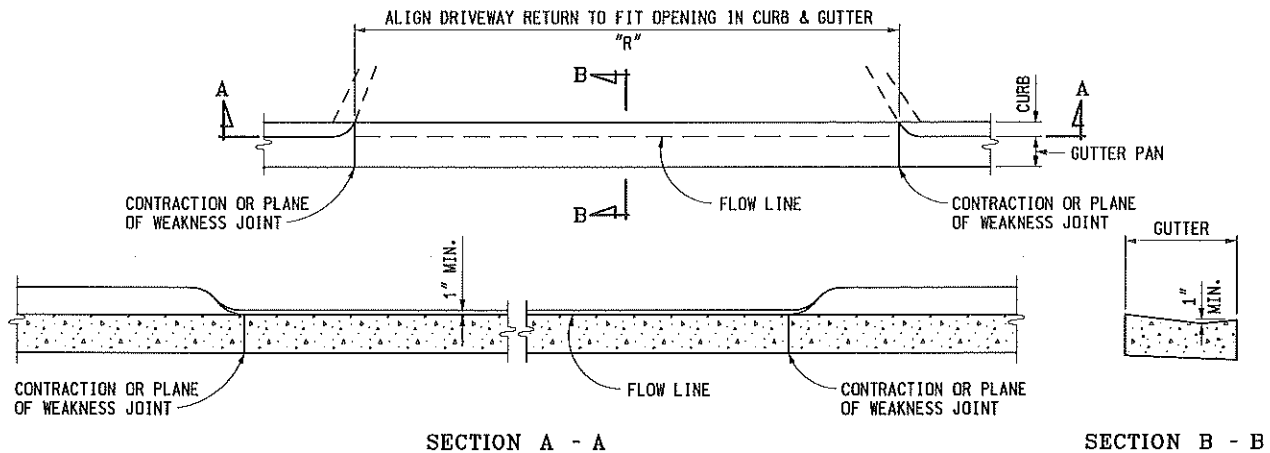

SECTION A - A
 CONCRETE DRIVEWAY OPENING, DETAIL L

SECTION B - B

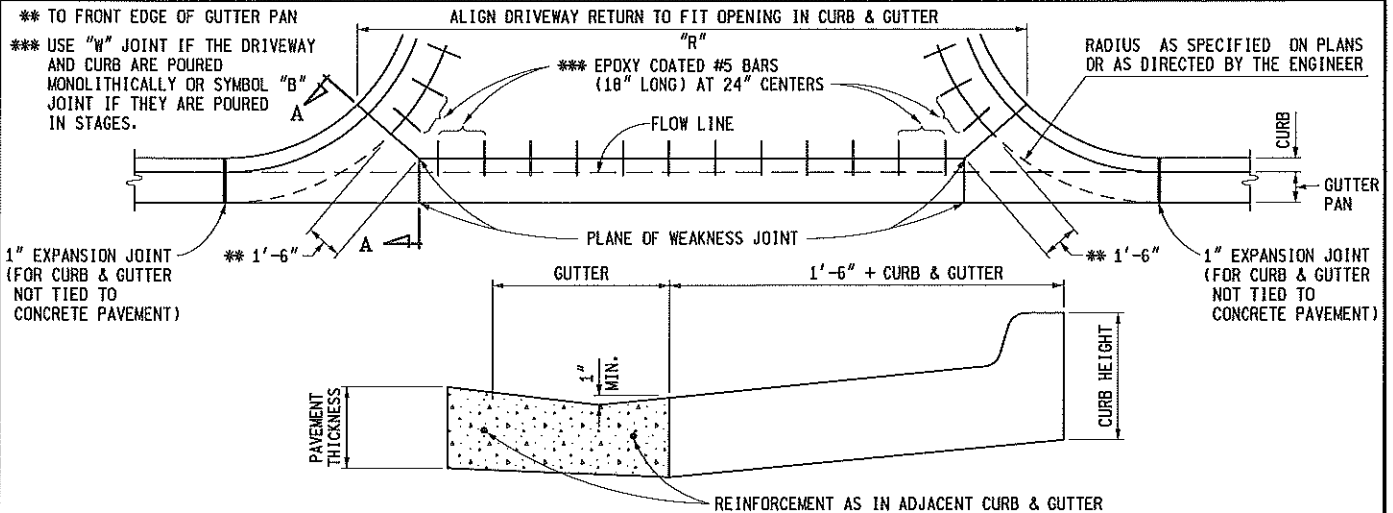

SECTION A - A
 CONCRETE DRIVEWAY OPENING, DETAIL M

NOTE:
 FOR ROADWAYS WITH CONCRETE PAVEMENTS, LONGITUDINAL LANE TIES WILL BE CONTINUOUS THROUGH THE DRIVEWAY OPENING AND THE SPACING OF THE #5 BARS IN CONCRETE DRIVEWAYS SHALL BE ADJUSTED TO AVOID CONFLICT WITH THE LONGITUDINAL LANE TIES.

MICHIGAN DEPARTMENT OF TRANSPORTATION
 BUREAU OF HIGHWAY DEVELOPMENT STANDARD PLAN FOR

DRIVEWAY OPENINGS
 & APPROACHES,
 AND CONCRETE SIDEWALK

9-30-2014
 F.H.W.A. APPROVAL

7-1-2014
 PLAN DATE

R-29-I

SHEET
 2 OF 4

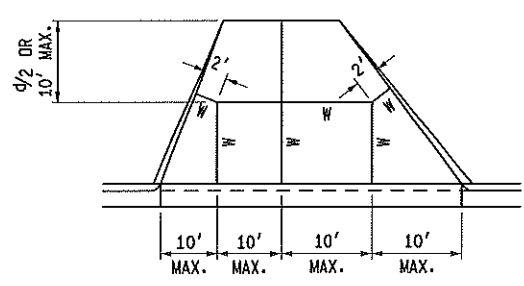
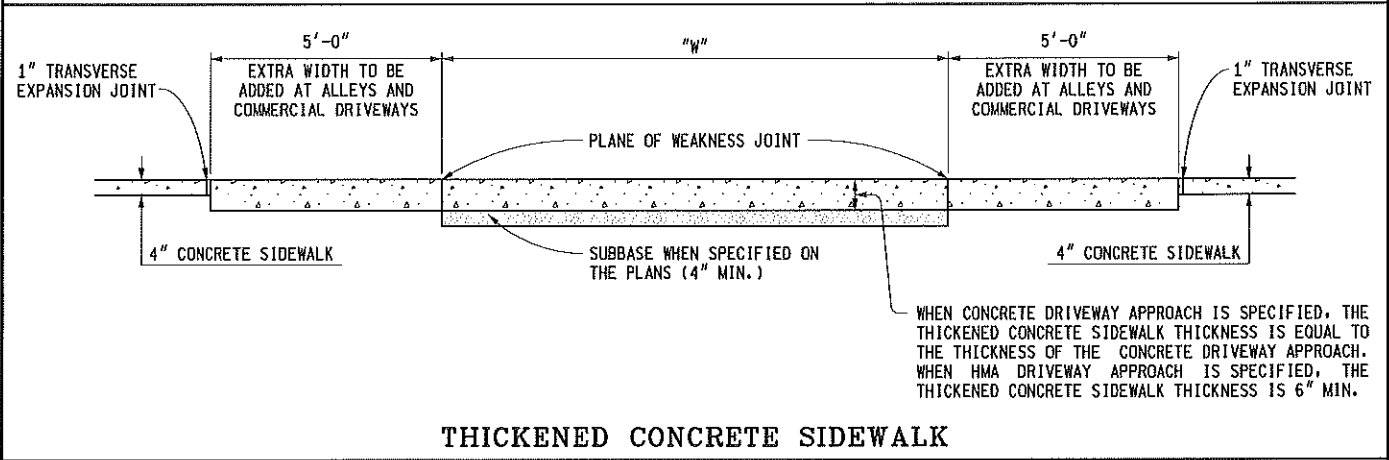
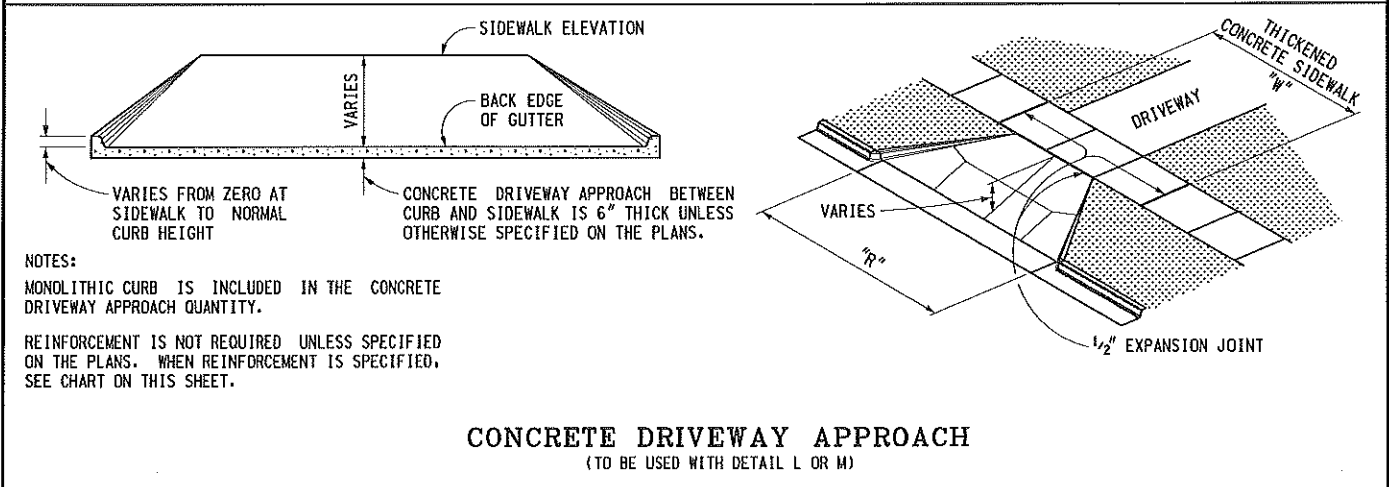
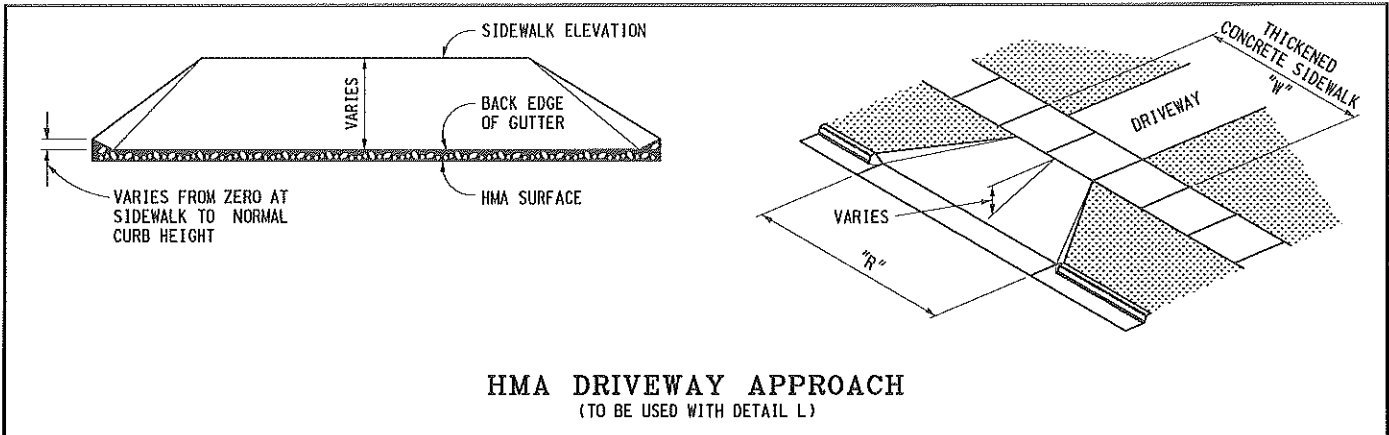

ADJUST DRIVEWAY JOINTS AS NEEDED TO ALIGN WITH ANY COINCIDING TRANSVERSE PAVEMENT JOINTS.
JOINT LAYOUT IS AS INDICATED OR AS DIRECTED BY THE ENGINEER.

INTERMEDIATE DRIVEWAY JOINT DETAILS

REINFORCEMENT FOR CONCRETE DRIVEWAYS		
CONCRETE DRIVEWAY THICKNESS	WIRE SIZE (6" x 6" MESH)	AVERAGE WEIGHT (LBS/100 SFT)
LESS THAN 8"	W1.4	21
	W2.9	42
8" OR GREATER	USE WIRE FABRIC REINFORCEMENT SPECIFIED ON STANDARD PLAN R-37-SERIES	

MICHIGAN DEPARTMENT OF TRANSPORTATION
BUREAU OF HIGHWAY DEVELOPMENT STANDARD PLAN FOR
**DRIVEWAY OPENINGS & APPROACHES,
AND CONCRETE SIDEWALK**

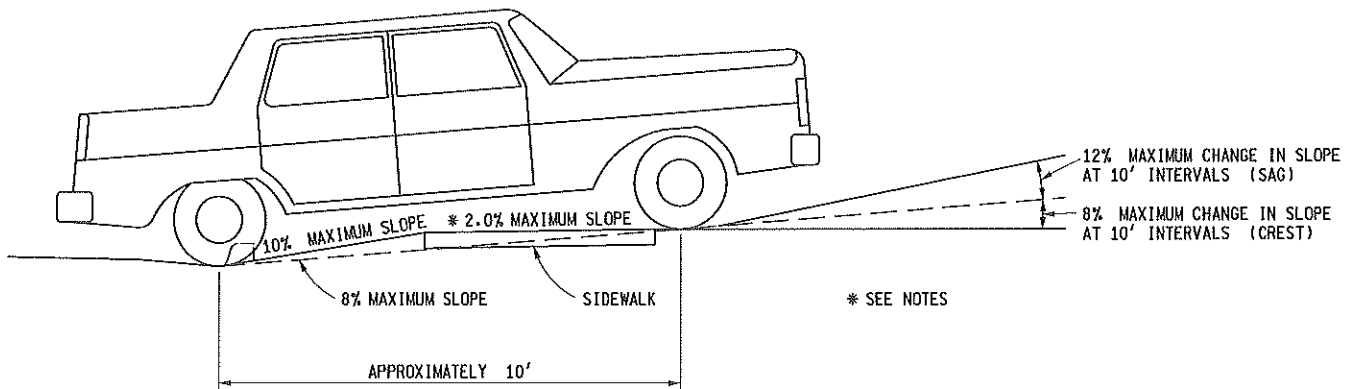

LOW VOLUME COMMERCIAL OR RESIDENTIAL DRIVEWAY SLOPES

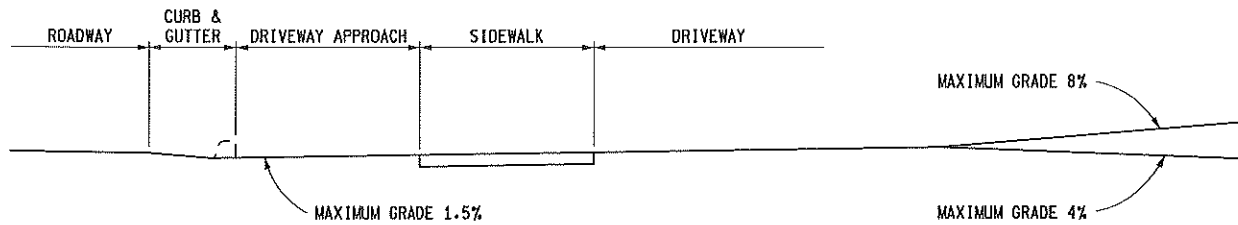

COMMERCIAL DRIVEWAY PROFILE FOR MAJOR TRAFFIC GENERATORS

NOTES:

FOR DRIVEWAY DESIGN REFER ALSO TO "ADMINISTRATIVE RULES REGULATING DRIVEWAYS, BANNERS, AND PARADES ON OR OVER HIGHWAYS" AND GEOMETRIC DESIGN G-680-SERIES, COMMERCIAL DRIVEWAYS.

FOR CURB AND GUTTER DETAILS, SEE STANDARD PLAN R-30-SERIES.

TRANSVERSE SIDEWALK SLOPES ARE TYPICALLY 1.5% (2.0% MAXIMUM). IN ORDER TO MEET SITE CONDITIONS, IF THE TRANSVERSE SLOPE IS REQUIRED TO BE LESS THAN 1.5%, LONGITUDINAL DRAINAGE MUST BE PROVIDED.

WHEN SETTING GRADES FOR COMMERCIAL DRIVES, THE TYPES OF VEHICLES USING THE DRIVE SHOULD BE CONSIDERED.

MICHIGAN DEPARTMENT OF TRANSPORTATION
 BUREAU OF HIGHWAY DEVELOPMENT STANDARD PLAN FOR
**DRIVEWAY OPENINGS
 & APPROACHES,
 AND CONCRETE SIDEWALK**

9-30-2014
 F.H.W.A. APPROVAL

7-1-2014
 PLAN DATE

R-29-I

SHEET
 4 OF 4

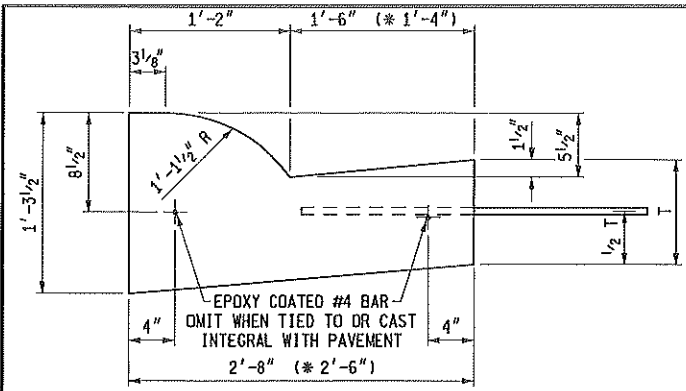

(* GUTTER PAN WIDTH MAY BE REDUCED WHEN APPROVED BY THE ENGINEER)

DETAIL	DIMENSION		LANE TIES	CONCRETE CYD / LFT	CONCRETE CYD / LFT
	T				
B1	9"	AS SHOWN	AS SHOWN	0.0900	(* 0.0855)
B2	9"	OMITTED	OMITTED	0.0900	(* 0.0855)
B3	10"	AS SHOWN	AS SHOWN	0.0941	(* 0.0894)

B

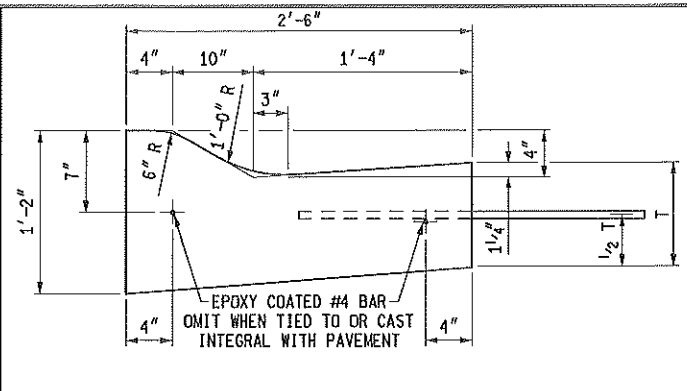

DETAIL	DIMENSION		LANE TIES	CONCRETE CYD / LFT
	T			
D1	9"	AS SHOWN	AS SHOWN	0.0788
D2	9"	OMITTED	OMITTED	0.0788
D3	10"	AS SHOWN	AS SHOWN	0.0826

D

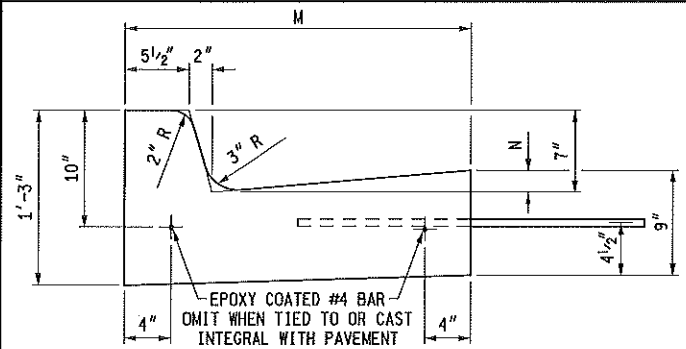

DETAIL	DIMENSION		LANE TIES	CONCRETE CYD / LFT
	M	N		
C1	1'-6"	7/8"	AS SHOWN	0.0506
C2	1'-6"	7/8"	OMITTED	0.0506
C3	2'-0"	1 3/8"	AS SHOWN	0.0632
C4	2'-0"	1 3/8"	OMITTED	0.0632
C5	2'-6"	1 7/8"	AS SHOWN	0.0757
C6	2'-6"	1 7/8"	OMITTED	0.0757

C

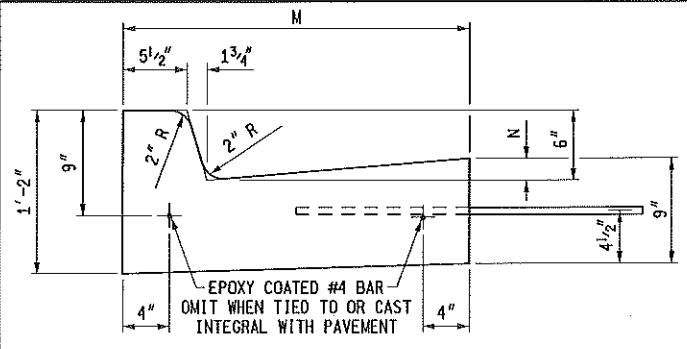

DETAIL	DIMENSION		LANE TIES	CONCRETE CYD / LFT
	M	N		
F1	1'-6"	7/8"	AS SHOWN	0.0484
F2	1'-6"	7/8"	OMITTED	0.0484
F3	2'-0"	1 3/8"	AS SHOWN	0.0610
F4	2'-0"	1 3/8"	OMITTED	0.0610
F5	2'-6"	1 7/8"	AS SHOWN	0.0737
F6	2'-6"	1 7/8"	OMITTED	0.0737

F

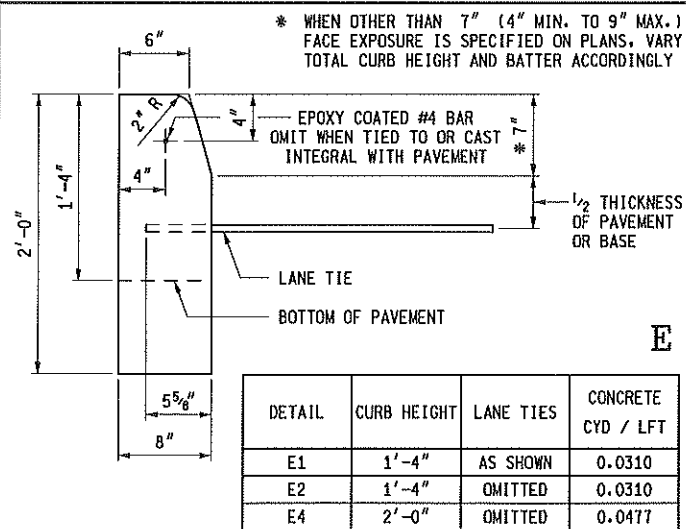

* WHEN OTHER THAN 7" (4" MIN. TO 9" MAX.) FACE EXPOSURE IS SPECIFIED ON PLANS, VARY TOTAL CURB HEIGHT AND BATTER ACCORDINGLY

DETAIL	CURB HEIGHT	LANE TIES	CONCRETE CYD / LFT
E1	1'-4"	AS SHOWN	0.0310
E2	1'-4"	OMITTED	0.0310
E4	2'-0"	OMITTED	0.0477

E



PREPARED BY
DESIGN DIVISION
DRAWN BY: B.L.T.
CHECKED BY: W.K.P.

DEPARTMENT DIRECTOR
Kirk T. Steudle

APPROVED BY: *Randy U. Puffel*
DIRECTOR, BUREAU OF FIELD SERVICES

APPROVED BY: *Paul A. Van Pelt*
DIRECTOR, BUREAU OF HIGHWAY DEVELOPMENT

MICHIGAN DEPARTMENT OF TRANSPORTATION
BUREAU OF HIGHWAY DEVELOPMENT STANDARD PLAN FOR

CONCRETE CURB AND CONCRETE CURB & GUTTER

9-30-2014
F.H.W.A. APPROVAL

2-6-2014
PLAN DATE

R-30-G

SHEET
1 OF 2

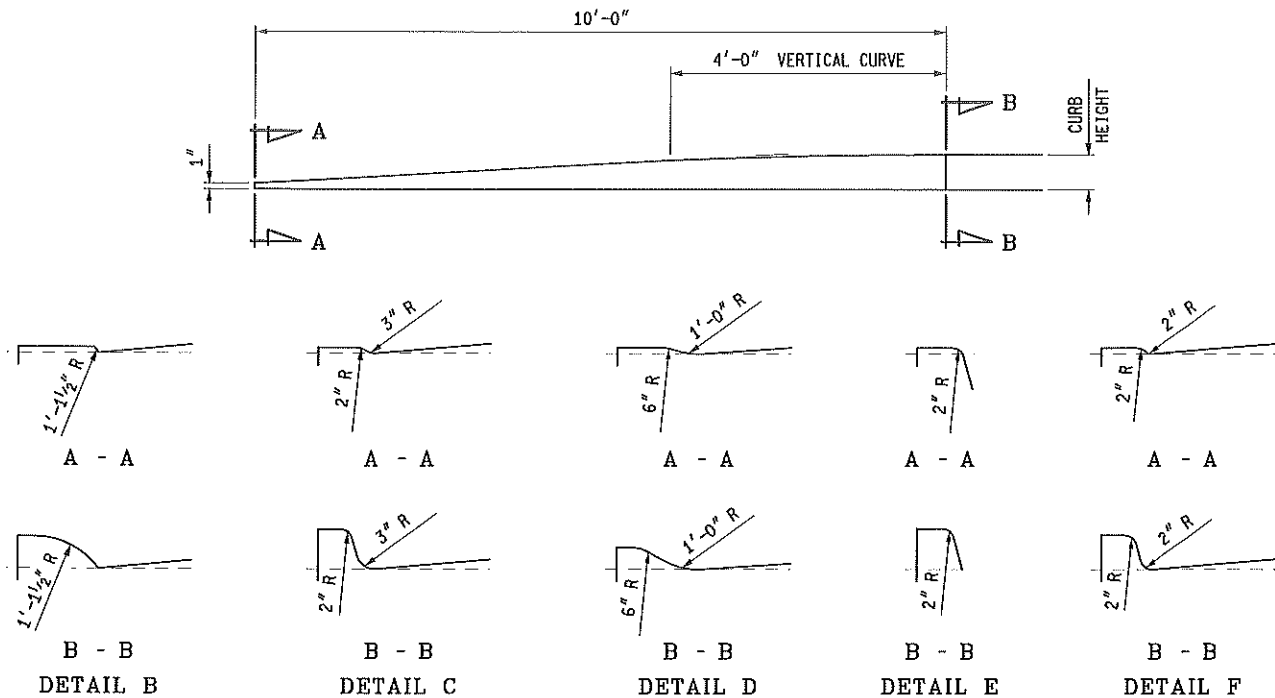

CONCRETE CURB, CURB AND GUTTER ENDINGS

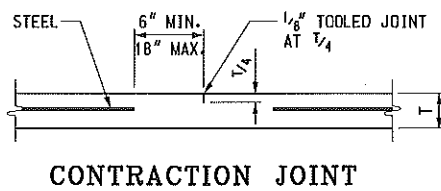
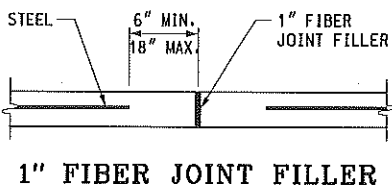

NOTES:

CURB AND GUTTER RADII SHALL BE DIMENSIONED TO THE FRONT EDGE OF THE GUTTER PAN OR EDGE OF PAVEMENT.

CONCRETE CURB AND GUTTER ENDINGS WILL BE PAID FOR IN LINEAR FEET OF THE ADJACENT CURB DETAIL.

JOINTS SHALL BE PLACED AT RIGHT ANGLES TO THE EDGE OF CONCRETE CURB AND GUTTER.

JOINTS DETAILED ON THE PLANS SHALL SUPERSEDE THOSE SPECIFIED ON THIS STANDARD PLAN.

BOTTOM SLOPE OF CURB AND GUTTER STRUCTURE MAY BE THE SAME SLOPE AS BOTTOM OF PAVEMENT. BACK OF CURB AND VERTICAL EDGE OF GUTTER PAN MAY HAVE A MAXIMUM 1/2" BATTER TO FACILITATE FORMING.

WHEN CURB AND GUTTER IS CAST INTEGRALLY, SEE CURRENT STANDARD PLAN R-31-SERIES.

ALL JOINTS FOR CURB OR CURB AND GUTTER ARE INCLUDED IN THE PAY ITEM FOR THE CURB OR CURB AND GUTTER.

JOINTS IN CURB OR CURB AND GUTTER NOT TIED TO CONCRETE PAVEMENT; ADJACENT TO CONCRETE BASE COURSE; OR ADJACENT TO HMA PAVEMENT:

- A. PLACE 1" FIBER JOINT FILLER AT 400' MAXIMUM INTERVALS.
- B. PLACE 1" FIBER JOINT FILLER AT SPRING POINTS OF INTERSECTING STREETS.
- C. PLACE 1/2" ISOLATION JOINT AT CATCH BASINS PER STANDARD PLAN R-37-SERIES.
- D. PLACE CONTRACTION JOINTS AT 40' MAXIMUM INTERVALS.

JOINTS IN CURB OR CURB AND GUTTER TIED TO JOINTED PAVEMENT

- A. PLACE 1" FIBER JOINT FILLER OPPOSITE ALL TRANSVERSE EXPANSION JOINTS IN PAVEMENT.
- B. PLACE 1/2" ISOLATION JOINT AT CATCH BASINS PER STANDARD PLAN R-37-SERIES.
- C. PLACE CONTRACTION JOINTS OPPOSITE ALL TRANSVERSE CONTRACTION JOINTS IN PAVEMENT.
- D. A SYMBOL (B) JOINT SHALL BE PLACED BETWEEN CURB OR CURB AND GUTTER AND ADJACENT CONCRETE PAVEMENT AS SPECIFIED ON STANDARD PLAN R-41-SERIES.

MICHIGAN DEPARTMENT OF TRANSPORTATION
BUREAU OF HIGHWAY DEVELOPMENT STANDARD PLAN FOR

**CONCRETE CURB AND
CONCRETE CURB & GUTTER**

9-30-2014 F.H.W.A. APPROVAL	2-6-2014 PLAN DATE	R-30-G	SHEET 2 OF 2
--------------------------------	-----------------------	--------	-----------------

APPENDICES

PRE-BID DOCUMENTS

SIGNED BIDDER DOCUMENTS

SIGNED AGREEMENT DOCUMENTS

CERTIFICATE OF LIABILITY INSURANCE

LETTER OF APPROVAL FROM ATTORNEY